



GAP/R  
K2  
SERIES

Applications Manual  
for PHILBRICK  
*OCTAL PLUG-IN*  
Computing Amplifiers\*

*\*and for solid state Differential Operational Amplifiers  
(with such modifications as common sense dictates)*

George A. Philbrick Researches, Inc.  
127 Clarendon Street, Boston 16, Massachusetts

K2-W

OPERATIONAL AMPLIFIER



K2-XA

OPERATIONAL AMPLIFIER

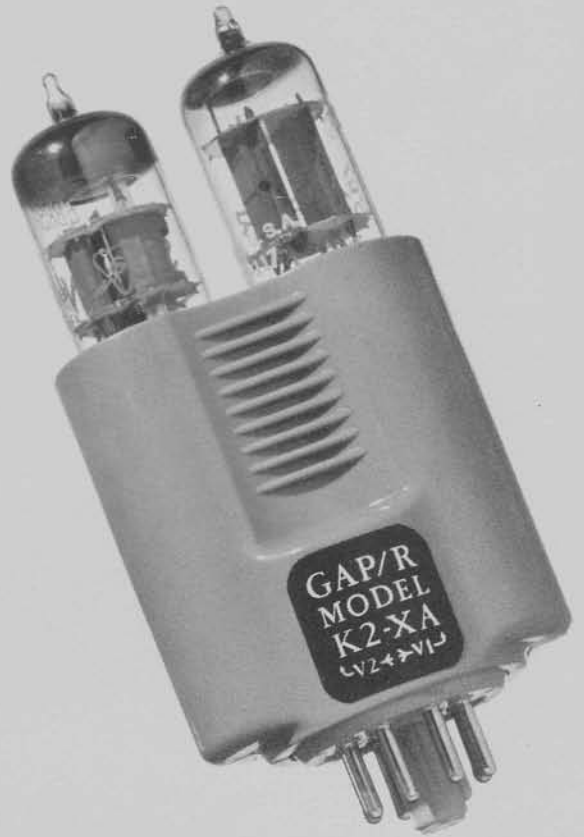

K2-P

STABILIZING AMPLIFIER



# A...A Brief on the Case at Hand

## A.0 WHY and WHEREFORE

The unusually favorable response to our *Palimpsest* has prompted us to prepare this booklet dealing with the theory, performance, and applications of Philbrick Computing Amplifiers. Detailed herein are the design features and functions of the GAP/R K2-Series Plug-in Amplifiers portrayed in the adjacent frontispiece.

Many specific uses are described, covering a wide range of circuits from simple inverters to complex multivibrators. Generally, each application involves but one amplifier. However, countless other computing and control instruments may be assembled permanently or *ad hoc* from interconnections of the modular components presented here.

Important new applications involving Philbrick "K-2s" are, of course, continually evolved, and hopefully will be broadcast in periodic supplements to this manual. For the interim, an ample supply of blank sheets and panels are bound into this pamphlet for reader convenience and initiative. (Why wait?)

## A.1 WHAT and WHO

Our principal in this case, the *operational amplifier*, is a direct-coupled amplifier designed to perform mathematical operations and transformations, usually by negative feedback. Such basic operations as summing, scaling, integration, and differentiation are readily performed; furthermore, combinations of these and other linear and nonlinear transformations can be implemented with equal facility.

Although direct-coupled amplifiers with negative or degenerative feedback have had a long and meritorious record in communication networks, the term "operational amplifier" came into vogue in the early 1940's. Prior to that time several inventors — G. A. Philbrick included — had independently applied such voltage amplifiers to computing networks.

There followed a decade of rapid development and application documented by considerable literature here and abroad. Some of the highlights of these developments have been gathered together and published by GAP/R in the *Palimpsest on the Electronic Analog Art* (Boston, 1955), as mentioned.

Philbrick Researches has gained eminence as a producer of versatile all-speed fully electronic analog components utilized as computers, automatic control devices and electronic measuring instruments.

## A.2 ANALYSIS and ANALOGY

If Mathematics can be called the "Queen of the Sciences", then truly Analogy is her consort. When logic is enlivened, existence theorems become self-evident.

By introducing *amplifiers* into physical structures to supply activation energies while enforcing signal flow causality, unlimited realms of abstraction may be physically realized. This does not mean, however, that Fictions may be made Truths; indeed learning to flatter rather than antagonize Nature is part and parcel of the Analog Art.

Specifically, using active circuits, one may construct an *Electronic Analog Computer*, a device using voltages to represent all variables. Such computers are used as research and development tools in the design and operation of industrial process controls, chemical reactions, electrical networks, and complex military systems, among others. They have especial value for dynamic systems, where vibration, stability, and response time are major design factors.

If relations and parameters are known, computation is a straightforward problem of solving algebraic and differential equations. However, analog computers also permit studies of systems where relations describing performance are not clearly known in advance. In this case, portions of the system may be *simulated* by active or passive networks constructed experimentally to give a behavior approximating known or desired response. Here operational amplifiers are used, for example, as isolating and amplifying elements between stages, scaling elements, lag or delay components, oscillators, regulators, as well as for basic mathematical operations.

Howsoever they arise, all computer representations of real or abstract systems are physical *Models*, but of extraordinary flexibility.

## A.3 CONTRIVANCE and CONTROL

Even a few moments with these tools in hand leads one to attempt to better the pallid past and attune with a fruitful future. The seeming vices of material processes can be turned to virtues through union of energy and entropy control. Lags can be made leads to predict the probable future from the known past. Instrument bridges may be monitored and balanced with continuous accuracy. Response data of processes may be digested immediately to enhance research and reward industry.

In electronic portions of closed-loop control systems and servomechanisms, operational amplifiers can be used as *brains* to command the *muscles*. The "error" between the ideal or desired condition and the existing condition is constantly measured by an input amplifier, and then (sometimes using the same amplifier) is amplified, transformed, scaled, and applied through power actuators to the process under surveillance as a corrective force to reduce the error. Stabilizing and compensating networks are conveniently implemented through subsidiary feedback operations.

In addition to the direct control applications indicated above, operational circuitry has been profitably used to simulate processes for testing and shakedown of prototype control systems and conversely for simulating projected controllers by actually operating existing plants, processes, or machines. Such uses have already enjoyed remarkable success in engine design and prime mover development; comparable promise is indicated in other fields.

The above realms briefly indicate possibilities of *instrumental* applications, wherein input signal information is transformed continuously into directly useful open- or closed-loop output actions.

# B . . . Philbrick Operational Amplifiers

## B.1 ANALOGY in GENERAL

Analogies are made possible by nature's wonderful system of structural parallelism in which a physical element in one medium may be represented by a corresponding physical element in another (e.g. mechanical *mass* may be represented by electric *capacitance*).

Analogs are of most assistance when an inherently inflexible system, or system of great cost, or of unknown performance is to be investigated. A problem may be rewritten so that, in effect, the plot remains the same but the names are changed, or, concretely, an analog may be set up in a more convenient system. The time scale may also be changed to suit one's convenience.

There are two forms of Analog devices, *passive*, less flexible and little used, and *active*, which allows flexibility limited only by the physical realisability of networks.

## B.2 ACTIVE ANALOGS

The active Analog may be represented generally by:

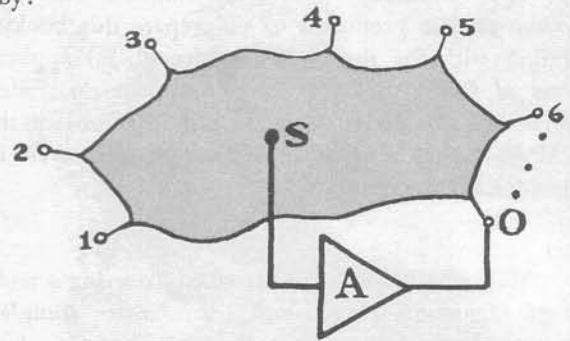

The shaded area represents any physically realisable network in any medium, having terminals 0, 1, 2, 3, . . . , and a node or *null* at S. The triangle A is an amplifier (hydraulic, pneumatic, mechanical or other) having high gain and a sign reversal. The node in the Network is maintained by A because the displacement of S (the *input* to A) is always  $\frac{1}{\text{gain of A}}$  of the output of A (the *apex* of triangle). Thus the sum of the forces applied to the network will be cancelled at point S. Hence the force at point 0 (the *output* of A) is influenced only by the Network and the forces applied to the network.

## B.3 OPERATIONAL AMPLIFIERS

The amplifier in an active Analog is called an *Operational Amplifier*. It is this amplifier which enforces the null in the Network and makes the performance of the Network depend only on its own parameters.

To accomplish such ends Operational Amplifiers for Analog Systems are usually amplifiers having high gain (producing large output changes for small input changes) and wide bandwidth (operating over a wide range of frequencies).

Mechanical, Hydraulic, Pneumatic, Electric and Electronic Analogs and Amplifiers are in use; the Electronic Analog being in general the most flexible and least costly. It is with the Electronic Analog that we are here primarily concerned.

Electronic Analogs are, in general, voltage node devices with all inputs and outputs in the form of *voltages*.

## B.4 ELECTRONIC AMPLIFIERS

Operational Amplifiers in Electronic Analogs are usually vacuum tube amplifiers having high input impedance for minimum loading, and low output impedance so that reasonable loads may be driven.

These amplifiers may be of the A.C. form (having a low frequency cut-off) or the D.C. variety (amplifying even slow changes). The D.C. type is to be preferred in general because the phase shift at low frequencies inherent in the A.C. form does not have to be taken into consideration in designing the computing network.

However, the design of D.C. amplifiers requires extreme care in choice of circuitry and components to insure minimum error. All GAP/R Operational Amplifiers are of this D.C. form.

**B.5 FUNCTION of AMPLIFIERS**

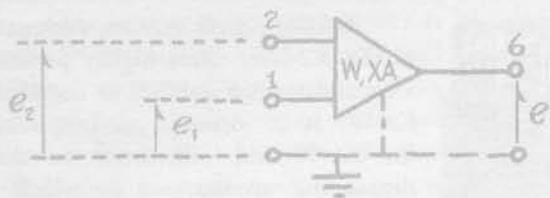

The schematic symbol of an operational amplifier which appears above uses a triangle to indicate the causal direction of signal flow. An internal ground reference is implied by the dashed lines. The Philbrick Operational Amplifiers K2-W and K2-XA are provided with balanced inputs,  $e_1$  and  $e_2$ .

The output  $e$  of an operational amplifier is related to its inputs as indicated below. A few millivolts variation of the differential input  $e_1 - e_2$  will swing the output  $e$  stably from full negative to full positive voltage as shown. The slope of the non-saturated portion determines the dc gain  $A$ .

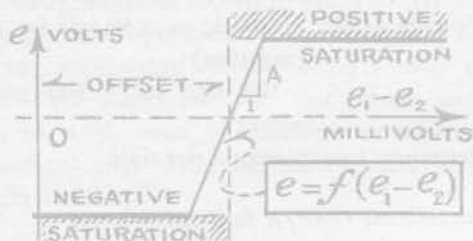

**B.6 AMPLIFIER CIRCUITS**

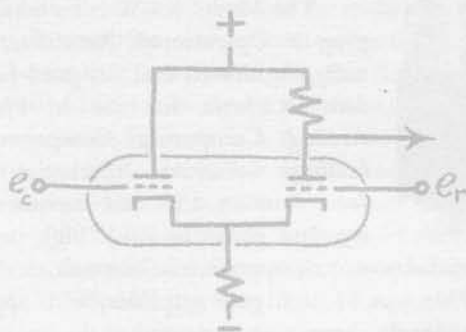

The diagram above depicts the input stage of the K2-W and K2-XA. The unique design of this stage allows true differential operation over a common input range of  $\pm 50$  volts while assuring high gain constancy, low grid current, and low drift. Using balanced differential amplifiers of this type, voltages applied to each grid produce output changes of equal sensitivity and opposite sign. This arrangement gives superior performance yet still permits the operation with the positive input,  $e_1$ , maintained at ground. However, many other operations become possible wherein the amplifier maintains the inputs at nearly equal potential. Such applications are outlined below and in the pages to follow.

**B.7 OFFSET and BIASING**

In the K2-W and the K2-XA, a small steady offset voltage exists between the two grids as of approximately 1.3 volts magnitude. The fluctuations in this offset are discussed under section D on Drift Stabilization.

In order to maintain a condition such that a zero volt differential input produces zero volts output, a steady bias must be placed between the inputs as outlined under Section E on Biasing Methods.

Throughout this manual we shall employ the symbolic convention below to denote an operational amplifier in which such biasing has been provided for.

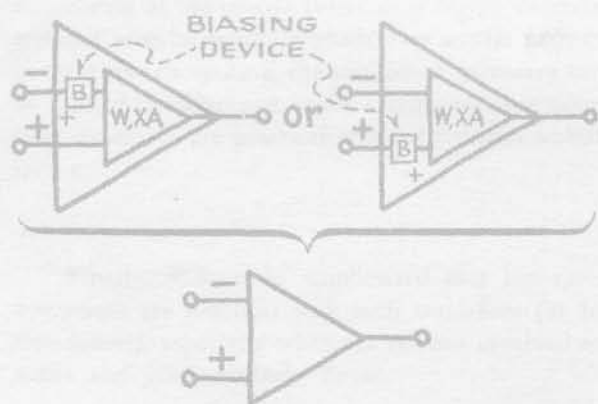

**B.8 SAMPLE APPLICATIONS**

The general nature of amplifier action can be appreciated from the circuit shown below. The absence of significant grid current causes  $i_1$  to equal  $i_2$ , and the gain of the amplifier ensures that  $e_c$  will follow  $e_r$  independently of any load that  $e$  must drive.

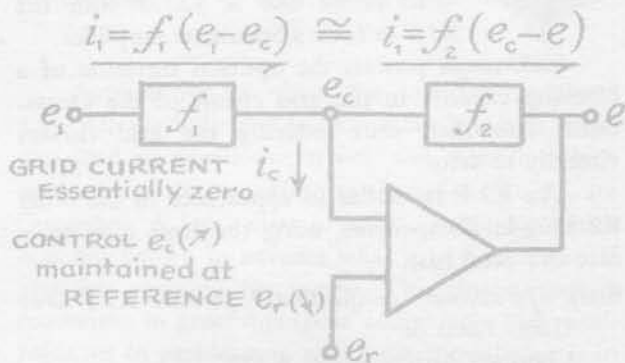

When  $e_r$  is grounded,  $e_c$  becomes zero. If, moreover, the perfectly general functional relations  $f_1$  and  $f_2$  became the linear operational impedances  $Z_1(p)$  and  $Z_2(p)$ , respectively, there results the well-known fact:

$$-e = \frac{Z_2(p)}{Z_1(p)} \cdot e_1$$

# C... Philbrick Plug-in Computing Amplifiers

## K2-W OPERATIONAL AMPLIFIER

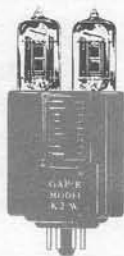

The Model K2-W is an octal-based plug-in Operational Amplifier, originally engineered and designed into this compact form for use in Philbrick Analog Computing Components. It features balanced differential inputs for minimum drift and maximum utility, and embodies both high performance and economy of operation in one unit.

This type of high gain amplifier, with appropriate feedback connections, maintains the two inputs at a nearly equal potential. Such properties give rise to a large number of operational applications.

*Brief operational specifications\* for the K2-W are:*

- Gain: 15,000 dc, open loop
- Power requirements: 6.4 Milliamps. at +300 vdc (Full load)
- 4.7 Milliamps. at -300 vdc (+50v)
- 0.6 amperes at 6.3v
- Input impedance: Above 100 megohms
- Output impedance: Less than 1K open loop
- Drift rate: 5 Millivolts/day, referred to input
- Voltage range: -50 vdc to +50 vdc at output and both inputs
- Response: 2 microsecond rise time

*\*For details see GAP/R Bulletin: K2-W*

## K2-XA OPERATIONAL AMPLIFIER

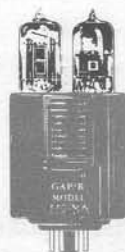

A more potent version, designated Model K2-XA, offers higher performance and similar stability to the Model K2-W. It is intended to supplement the K2-W and will serve for more demanding applications in which its higher power consumption and slightly greater cost may be justified.

This model will perform all of the functions attributed to the Model K2-W. It plugs into the same octal sockets and employs the same connections for power and for computing signals.

*Brief operational specifications\* for the K2-XA are:*

- Gain: 30,000 dc, open loop
- Power requirements: 11.4 milliamps. at +300 vdc (Full load)
- 8.0 milliamps. at -300 vdc (+100v)
- 0.75 amperes at 6.3v
- Output impedance: Below 300 ohms, open loop
- Voltage range: -50 vdc to +50 vdc for inputs (together):
- 100 vdc to +100 vdc for output
- Response: 1 microsecond rise time

*\*For details see GAP/R Bulletin: K2-XA*

## K2-P STABILIZING AMPLIFIER



GAP/R Model K2-P is a chopper amplifier designed to stabilize an Operational Amplifier such as Model K2-W or K2-XA. The low drift rate of the K2-W or K2-XA, 5 millivolts per day, is reduced to a sub-millivolt level, when either one is *paired* with the K2-P to form a Stabilized Amplifier.

Such usage permits the optional inclusion of a blocking capacity in the grid circuit of the Operational Amplifier, thus reducing the grid current virtually to zero.

The K2-P is similar in appearance to the other K2 Plug-in Components, using the same case structure and octal base.

*Brief operational specifications\* for the K2-P are:*

- Gain: 1,000 dc
- Chopper: Airpax Model A-172
- Power requirements: 2.4 milliamps, at 300 vdc
- 0.45 amperes at 6.3v 50-60 cps
- Input impedance: 1 Megohms dc chopped to ground
- Output impedance: 22 megohms and 1  $\mu$ f
- Stability: Inherently below 0.1 mv
- Response: Substantially a single lag of at least 22 sec. time constant

# D... Drift Stabilization of Operational Amplifiers

## D.1 ORIGIN and INFLUENCE of DRIFT

What is this thing called Drift? It is simply a gradually-developing offset in the null voltage of feedback amplifiers. Well-engineered electronics can keep the figure within limits which are better than tolerable for most applications. Further, such offset will produce no error at all in many ac computing systems.

Inherent compensation of drift is best achieved with balanced amplifier inputs, employing stable triodes; of course, the power supply sources should also be steady. The most economic answer lies in using both techniques, and Philbrick has an enviable record of practical achievement in this department.

For applications requiring small drifts, one may frequently use operational amplifiers in pairs: so that any appreciable drifts—being similar on the whole—are subtracted out. But where accuracies down to 0.1% must be attained, or where drifts accumulate, true artificial stabilization must be brought to bear.

## D.2 DRIFT STABILIZATION

While it is quite possible to make an entirely electronic amplifier which will respond reliably to much better than 1 millivolt dc, this is more readily accomplished in a slow device which includes a standard modulator. Since such a device, as with the inherently stabilized units, has applications in its own right, it is sound economics to produce this action separately in a plug-in which will convert the simpler structures to stabilized Operational Amplifiers when needed. The Stabilizing Amplifier is known as Model K2-P, and is described in Section C of the present document.

When employed in an octal socket next to a K2-W (or K2-XA), with similar power connections, two wires will connect the K2-P for stabilizing, giving millivolt drift-correction. Biasing methods for still closer correction are described in Section E.

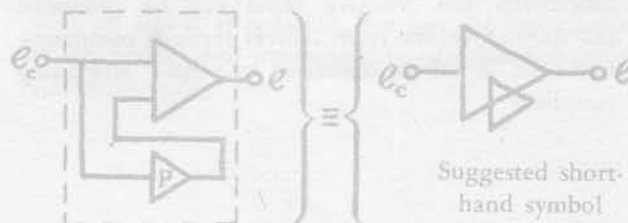

## D.3 UNSTABILIZED OPERATION

Low-drift, unstabilized Operational Amplifiers such as the Modules K2-W and K2-XA will operate to complete satisfaction in the great bulk of instrumental and computing applications.

This is true first of all for ac operations, where the variations only of signals are important. The largest usage has been in high-speed repetitive systems in which stable closed loops predominate, and it is relevant that such systems are of overwhelming import. When nonlinear systems are involved, simple monitoring of the crucial variables is highly effective, and may even be made automatic over secular periods. In repetitive computing, the method of symmetry may be applied to advantage, to the extent that even open-loop structures are practical without artificial stabilization.

Finally, it must be emphasized that low-speed operations are practical with such amplifiers (as for Simulation), especially when the systems involved are stable and predominantly linear.

## D.4 STABILIZED OPERATION

As outlined above, the Philbrick Stabilized Operational Amplifier is a "team" comprising the Model K2-P Stabilizing Amplifier in tandem with a K2-W or K2-XA Operational Amplifier. The two members of this team may be applied also to individual missions in which each excel alone.

Applications in which the complete stabilized amplifier are indicated include those in which drifts may lead to cumulative errors, and those in which accuracies of dc operation in the order of 0.1% are demanded. A large class of usage is that for which it is not known in advance what is to be the sort of precision required for success. This circumstance is commoner in general-purpose assemblages and manifolds, or in problems in which the formulation is in very early or conjectural stages.

Please remember that you can easily obtain expert advice on unusual applications from the engineers of Philbrick Researches. No problem is too trivial, or too grandiose, for our enthusiasm.

# E... Biasing Methods

E.1 CELL in PLUS INPUT

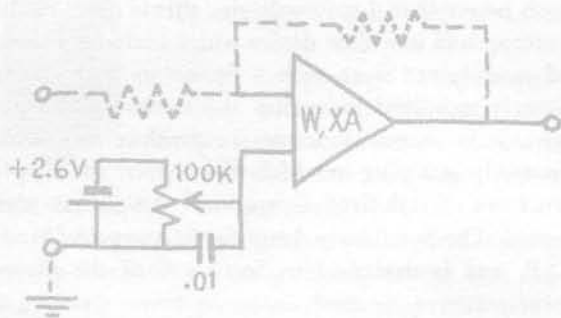

This arrangement uses a primary cell in the positive input but leaves both inputs available for differential use. Positive input can be grounded (as shown), driven from sources through computing networks, or can be connected to a K2-P Stabilizing Amplifier.

E.2 CELL in MINUS INPUT

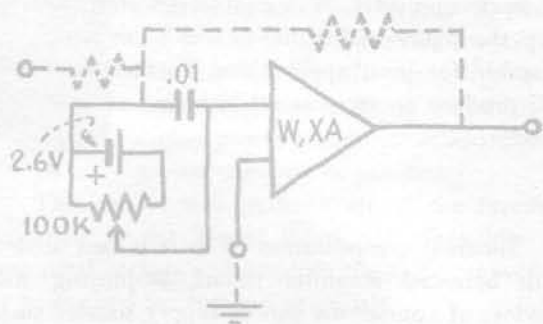

Shown is a configuration similar to that previous but now with the biasing cell in the negative input. This results in low distributed capacitance on the positive input.

E.3 DIRECT BIASING

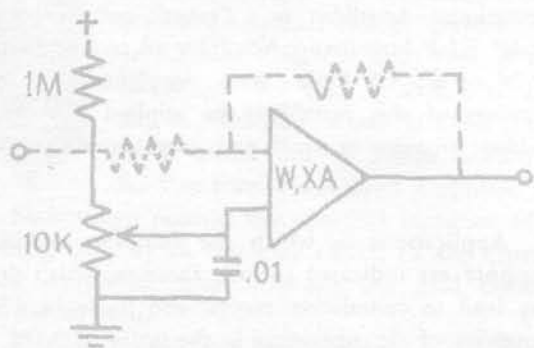

This circuit avoids the use of biasing cells, and is useful where the plus input is not needed.

E.4 DIRECT ADDING

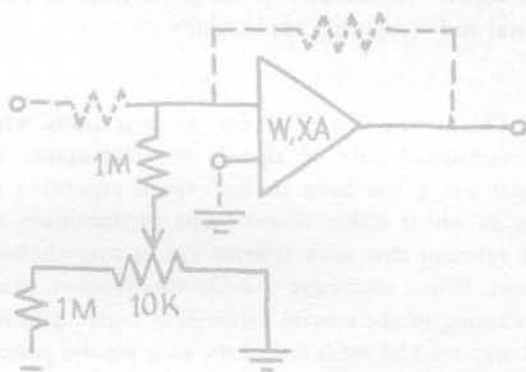

By shifting the biasing circuit to the negative side in the form of a constant adder, the plus input, although shown ground, becomes generally available.



# E... Biasing Methods (continued)

## E.5 FOLLOWER FORMS

The next three circuits indicate some biasing methods which are particularly advantageous when operational amplifiers are used as voltage followers.

The advantages and drawbacks of each are indicated.

## E.6 CELL BIAS

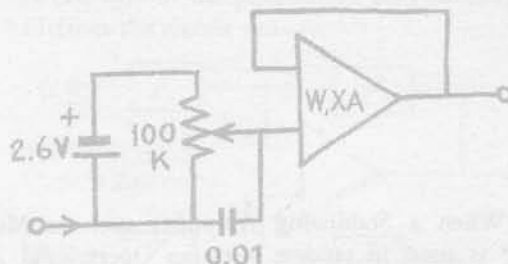

This circuit provides a high input impedance with no signal attenuation, but has the capacitance of the battery and potentiometer to ground shunted across the input.

## E.7 CELL BIAS

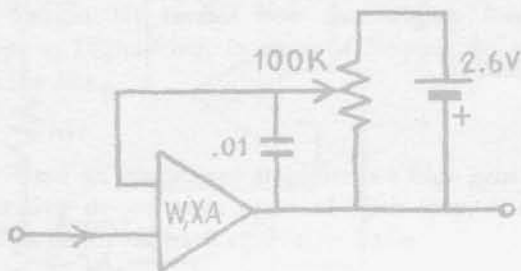

Biasing as shown above also provides high impedance at the input but transfers the cell capacitance to the low impedance (output) side.

## E.8 DIRECT BIASING

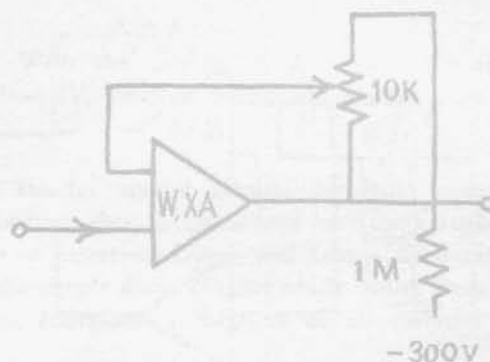

Here no cell is required for biasing, but the follower is left with a gain of approximately 1.003 due to the attenuation of feedback. However, this can be offset using a constant current source in place of the 1 megohm resistor.

# E... Biasing Methods (continued)

## E.9 STABILIZED FORMS

When a Stabilizing Amplifier such as Model K2-P is used in tandem with an Operational Amplifier, slightly altered forms of biasing become appropriate for this arrangement. A few of these are given in adjacent panels.

## E.10 CELL in PLUS INPUT

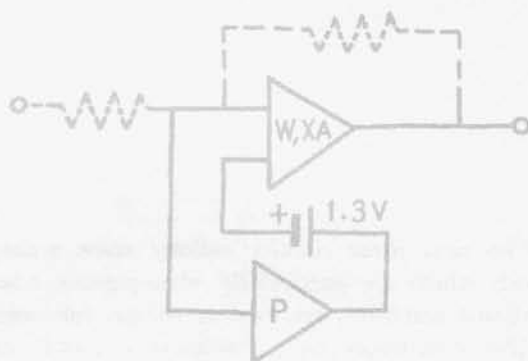

In this form, a 1.3 volt cell is placed in series with the positive input. Although the offset of the amplifier may vary  $\pm 100$  millivolts from this voltage, the K2-P will reduce this error by its gain of 1000.

## E.11 BLOCKING CONDENSER METHOD

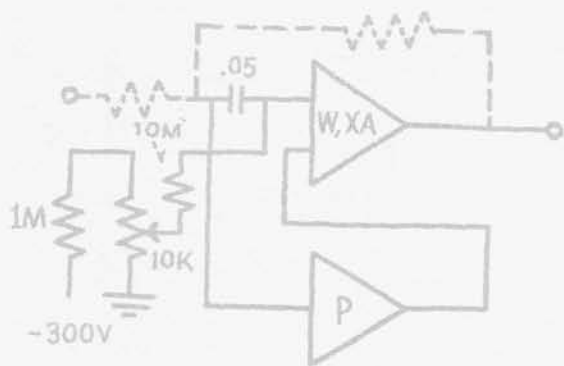

This arrangement avoids the use of a cell but produces additional difficulties in recovery from overload conditions.

## E.12 CURRENT INJECTION METHOD

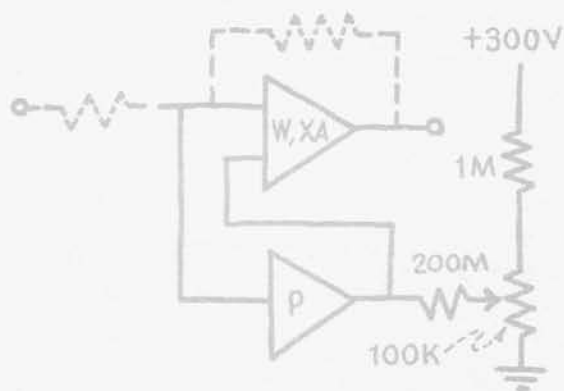

Here the cell is eliminated, together with overload burdens, but at the cost of approximately 10% in the gain of the K2-P.

# F... Applications and Circuits using Philbrick Amplifiers

## F.1 POSITIVE INPUT GROUNDED

Section I to follow deals with circuits in which the reference input is maintained at zero.

A representative example arises in the case of the circuit depicted thus:

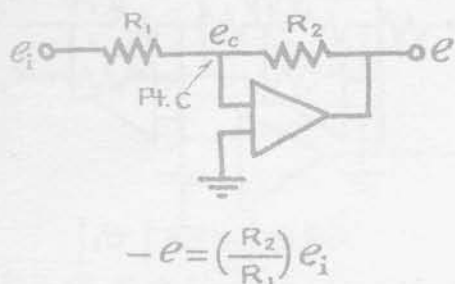

$$-e = \left(\frac{R_2}{R_1}\right) e_i$$

This scale changing circuit acts precisely like an *electronic lever*, but one which "floats" in its fulcrum so that deflections at this fulcrum provide a signal  $e_c$  to the amplifier to position the output side of the lever regardless of the load (within design limits). Thus a strict analogy exists in these applications between computing amplifiers and their hydraulic and pneumatic counterparts in the "brains" of industrial control systems.

Of course, vastly more articulate operations become possible when reactive networks replace the simple input and feedback resistors  $R_1$  and  $R_2$ .

## F.2 POSITIVE INPUT ACTIVE

In Section II, circuits are detailed which illustrate the advantages accruing through use of the reference input.

A fair idea of the possibilities thus afforded may be had from the circuit shown:

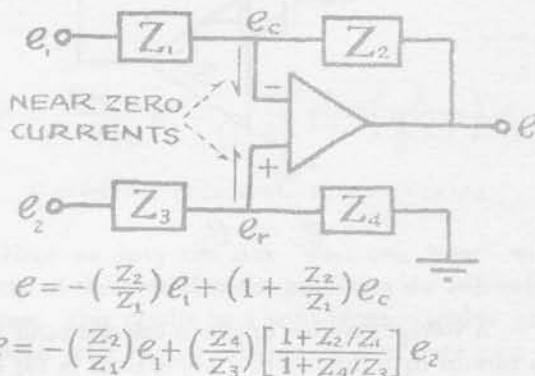

$$e = -\left(\frac{Z_2}{Z_1}\right) e_i + \left(1 + \frac{Z_2}{Z_1}\right) e_c$$

$$e = -\left(\frac{Z_2}{Z_1}\right) e_i + \left(\frac{Z_4}{Z_3}\right) \left[\frac{1 + Z_2/Z_1}{1 + Z_4/Z_3}\right] e_2$$

Thus by suitable choice of the indicated impedances a large number of fairly complex operational transformations may be performed by a *single amplifier!*

However, the heavy use of passive circuitry that the above implies often results in grave restrictions on range of variation and adjustment, so that such circuitry is generally more valuable in fixed, special purpose arrangements.

## F.3 LIMIT-TO-LIMIT OPERATION

Section III reveals how the Mighty Analog stoops to Digitalizing, in terms of flipping, flopping and the like.

Since an operational amplifier is a high gain but saturating device when operated open loop, it may readily be driven hard against its limits.

If weak regenerative resistive feedback is used, a static hysteretical switch results. Various combinations of negative dynamic feedback then can yield an unlimited variety of vibratory switches and oscillators.

Such devices have many instrumental applications, in addition to their obvious use as signal generators for analog computer installations.

## F.4 NONLINEARITY and SPECIALTIES

With the advent of Nonlinear Circuitry in Section IV, limitless thresholds abound.

Besides special circuits involving operational amplifiers, there is introduced here the valuable concept of Selection, Upper and Lower. By iterated use of the simple diode circuits which realize these operations, functional constraints of all varieties result.

Thereby, for example, multiplication and function generation are made possible simply and accurately. Such operations follow directly from the circuits described.

# 1 . . . Circuits with Positive Input Grounded

1.1 INVERTER

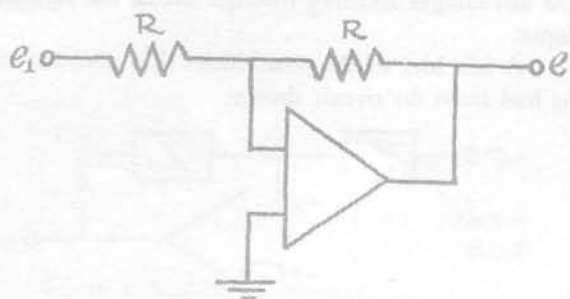

$$-e = e_1$$

A voltage inverter, or one-to-one electronic lever, is formed by using identical impedances in the input and feedback paths. The impedances are usually purely resistive, but for some cases use of reactive elements will improve overall response.

Inverters are used wherever sign changes are necessary or for shifting the phase of a signal precisely 180°. Combined with the inverting adder below, an inverter makes voltage subtraction possible.

1.1a INVERTER PAIR

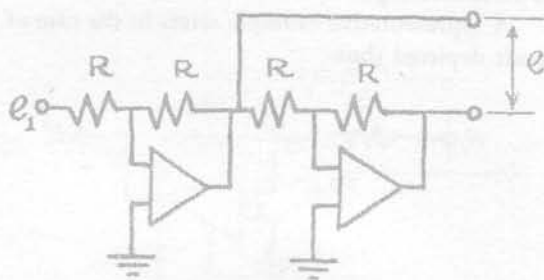

$$|e| = 2|e_1|$$

Two inverters may be used in tandem, replacing center-tapped transformers, to provide a high performance balanced source from an unbalanced, one-sided signal, for push-pull operation.

For example, when the input varies from  $+e_1$  to  $-e_1$ , the output  $e$  taken across the pair, varies from  $+2e_1$  to  $-2e_1$ . Thus a pair of K2W's can drive an oscilloscope through  $\pm 100$  volts.

1.2 ADDER (Inverting)

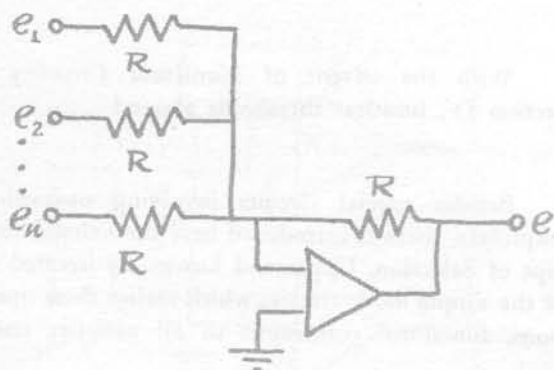

$$-e = e_1 + e_2 + \dots + e_n$$

Summation operations are performed by a network as shown. When  $n$  input voltage signals  $e_1, e_2, \dots, e_n$ , are applied to the input terminals, the voltage sum,  $-e$ , is delivered at the output terminal. The circuit also acts as a one-to-one inverter with respect to each input.

1.3 LINEAR COMBINOR (Inverting)

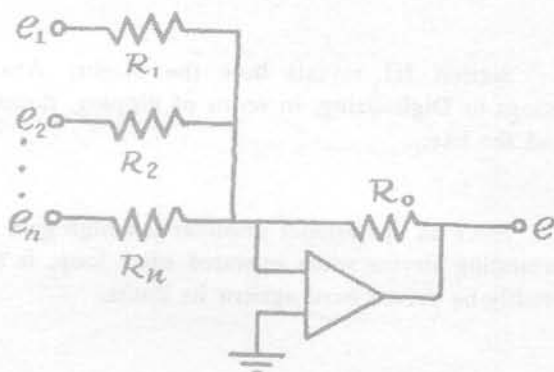

$$-e = \left(\frac{R_0}{R_1}\right)e_1 + \left(\frac{R_0}{R_2}\right)e_2 + \dots + \left(\frac{R_0}{R_n}\right)e_n$$

By modifying the adder circuit (1.2) to provide unequal input resistors, a more general form of weighted summer results. This circuit can produce an output equal to the linear combination of several voltage inputs, with coefficients normally fixed.

# ... Circuits with Positive Input Grounded (continued)

1.4 WEIGHTED AVERAGER (Inverting)

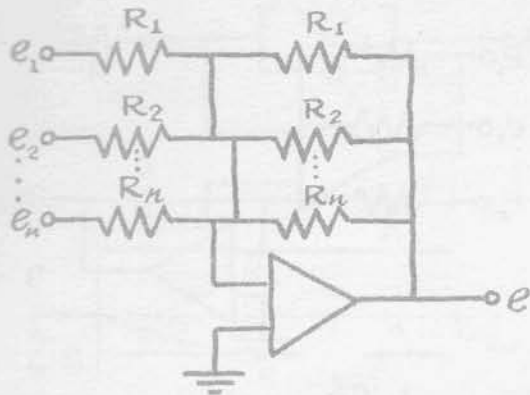

$$-e = a_1 e_1 + a_2 e_2 + \dots + a_n e_n$$

$$\text{where } a_k = \frac{1/R_k}{1/R_1 + 1/R_2 + \dots + 1/R_n}$$

$$\text{and where } a_1 + a_2 + \dots + a_n \equiv 1$$

A special case of the Linear Combinor (1.3) utilizes matching resistors in a voltage-dividing network which assures that the sum of the weighting coefficients is always precisely unity. This yields an output which is the inverted weighted average of the inputs.

1.5 COEFFICIENT (Inverting)

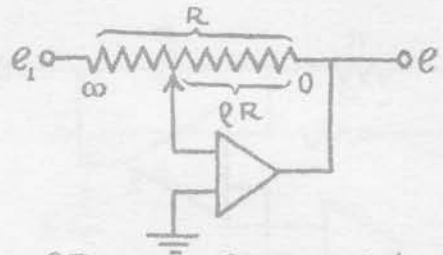

$$-e = \frac{\rho R}{(1-\rho)R} e_1 = \frac{\rho}{(1-\rho)} e_1 = \left( \frac{1}{\frac{1}{\rho} - 1} \right) e_1$$

$\rho$  = FRACTIONAL ROTATION

Here we have the true "electronic lever" with the tap of the potentiometer providing the adjustable fulcrum. This results in a wide-range, variable gain amplifier with precise calibration. A voltage gain of  $-1$  occurs at mid-setting while gains from a precise zero to very high values are within range. Note that for  $\rho$  near unity, the input impedance becomes very small so that care must be taken not to overload the previous stages.

Coefficient or proportioning elements are useful for direct settings of local sensitivities. In analog structures, most parameters can be embodied and varied by this means.

1.6 ADJUSTABLE LINEAR COMBINOR

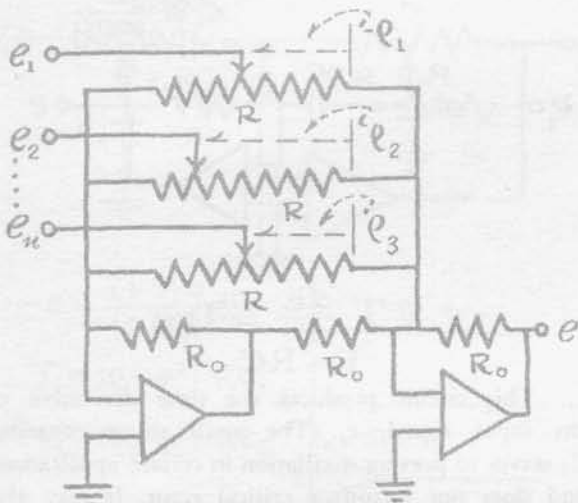

$$e = \left( \frac{R_0}{R} \right) \left[ \frac{2\rho_i - 1}{\rho_i(1-\rho_i)} \right] e_i + \dots \text{etc.}$$

A fully adjustable linear combinator is formed as indicated using two amplifiers. Mid-setting of each potentiometer gives zero influence coefficient, while full scale traverse ranges from  $-\infty$  to  $+\infty$ .

1.7 LINEAR SCALE COEFFICIENT

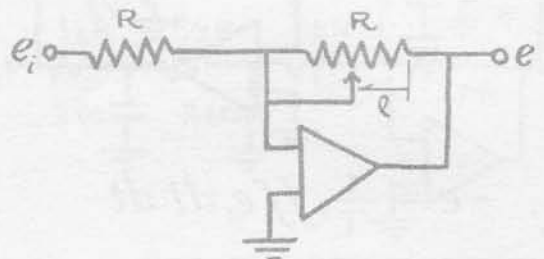

$$-e = \frac{\rho R}{R} e_i = \rho e_i$$

If the potentiometer is placed in the feedback path alone, a proportioning device is obtained with narrower range than that of (1.5), but having a linear scale with respect to potentiometer rotation.

# I . . . Circuits with Positive Input Grounded (continued)

1.8 TIME INTEGRATOR (Inverting)

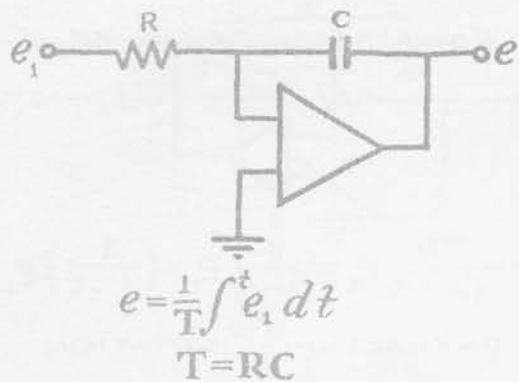

An operational amplifier with capacitance feedback and resistive input will provide the inverted time integral one of the input voltage signal.

In "open-loop" applications, the output (or capacitor) voltage will generally have to be reset to zero by an external clamping or discharging device; this may be most simply accomplished by putting a manual or relay switch across the condenser as indicated.

Integrating is usually to be preferred over differentiation for the reasons cited under Circuit (1.11).

1.9 SUMMING INTEGRATOR (Inverting)

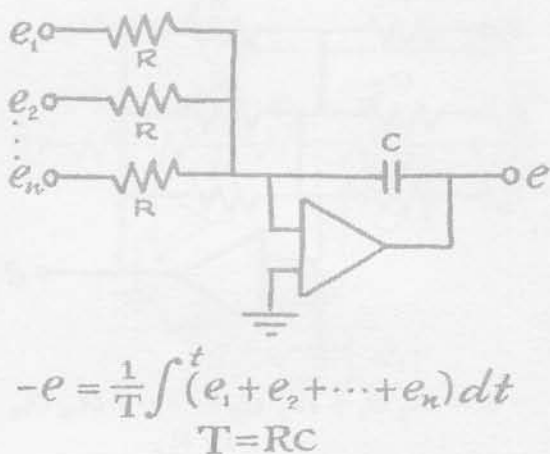

By providing a multiplicity of input resistors, the Circuit (1.8) is generalized to a Summing Integrator.

Again, by varying the values of these input resistors, weighting factors may be impressed on the inputs.

By replacing the feedback resistors of Circuit (1.6) with condensers, a fully adjustable Weighted Summing Integrator is obtained.

1.10 DOUBLE INTEGRATOR (Inverting)

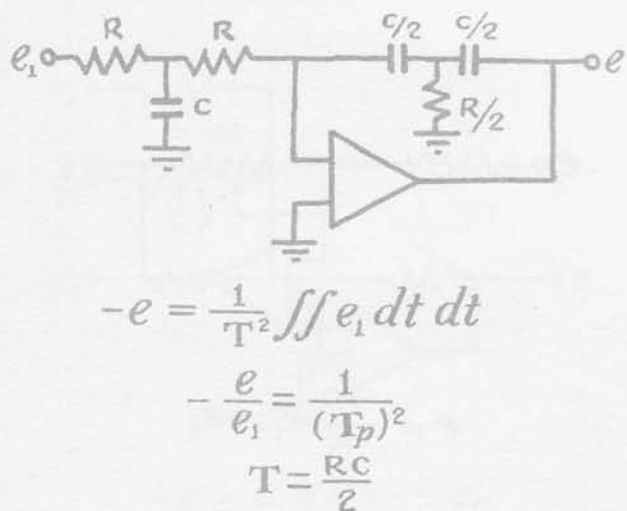

Another extension of Circuit (1.8) permits a single amplifier to generate the second time integral of an input signal. This element is sometimes useful for handling dynamic system equations such as

$$\frac{d^2 x}{dt^2} + ax = f(t)$$

1.11 DIFFERENTIATOR (Inverting)

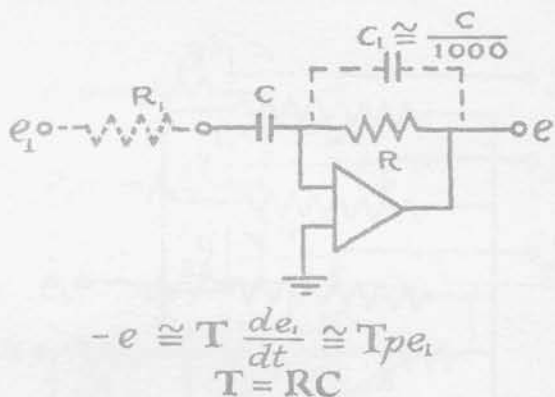

This circuit produces the time derivative of the input signal,  $e_1$ . The small shunt capacitor  $C_1$  serves to prevent oscillation in certain applications and does not introduce critical error. It may also sometimes be necessary to add a small resistor  $R_1$ , in series with the input capacitor.

Since differentiation will decrease signal-to-noise ratio while integration does the opposite, complex systems are best handled making maximum use of the latter operation. However, because such a circuit produces, for example, a pulse from a step, it has many instrumental applications not normally termed computing.

# Circuits with Positive Input Grounded (continued)

1.12 FIXED LAG (Inverting)

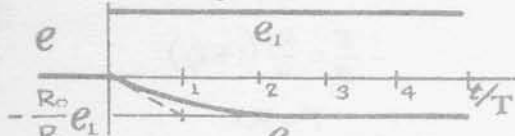
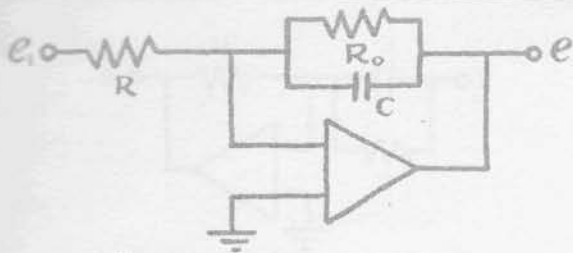

$$e + T \frac{de}{dt} = -\frac{R_0}{R} e_1$$

$$-\frac{e_0}{e_1} = \left(\frac{R_0}{R}\right) \frac{1}{1 + T_p}$$

$$T = R_0 C$$

A first order "lagging" or tardigrade operation is performed by this circuit containing a parallel  $R_0C$  network in the feedback path. Variation in  $R_0$  will produce proportional changes in both gain and time constant.

Combining this "Time Average" with the Signal Averager (1.4) produces another useful instrument circuit.

1.13 ADJUSTABLE LAG (Inverting)

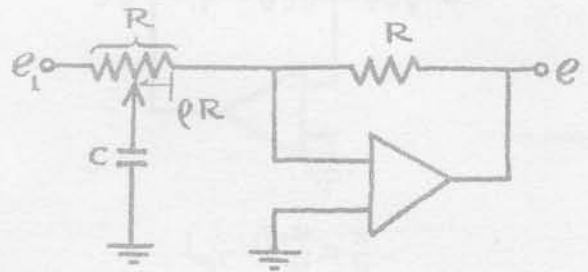

$$-e = \frac{1}{1 + T_p} e_1$$

$$T = (e - e^2) RC$$

An input impedance consisting of a potentiometer connected as shown with a capacitor tap will provide a fully adjustable lag, maintaining unit gain and having a parabolic calibration about the maximum (central) value of lag time.

1.14 VARIABLE LEAD-LAG (Inverting)

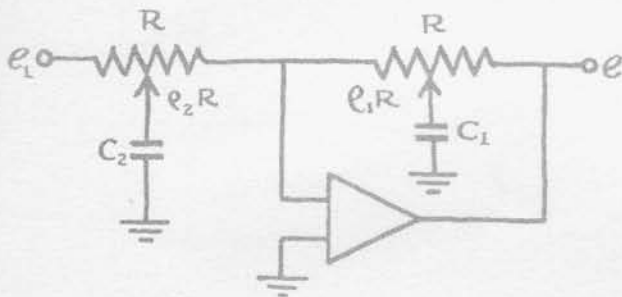

$$-e = \frac{1 + T_1 p}{1 + T_2 p} e_1$$

$$T_1 = (e_1 - e_1^2) RC_1$$

$$T_2 = (e_2 - e_2^2) RC_2$$

$e_1, e_2$  are Rotation

Using the previous input circuit also in the feedback path produces a leading or lagging action depending upon the relative weights of  $T_1$  and  $T_2$ . This circuit is useful as a "lead-lag" compensating element in instruments and controllers. It also has many applications in the representation of thermal systems.

1.15 PHASE SHIFTER or TIME DELAY

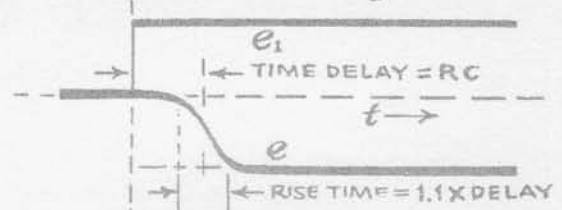
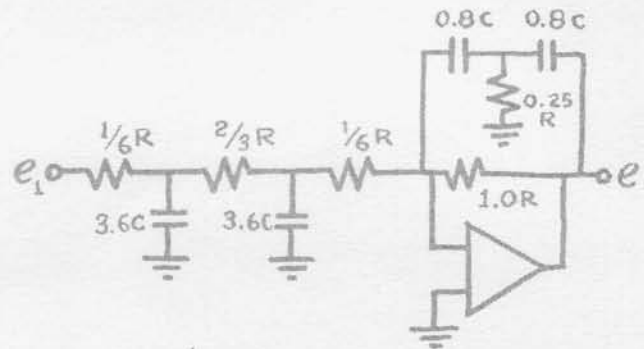

A unit gain phase shift or transmission delay is approximated by this circuit, with non-overshooting response as indicated.

Interconnecting a cascade of any such delays yields a total delay equal to the sum of individual delays and a rise time equal to the square root of the sum of the squares of each rise.

# I . . . Circuits with Positive Input Grounded (continued)

1.16

AUGMENTING INTEGRATOR

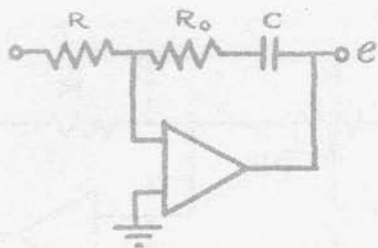

$$-\frac{e}{e_1} = \frac{R_o}{R} \left(1 + \frac{1}{T_p}\right)$$

$$T = R_o C$$

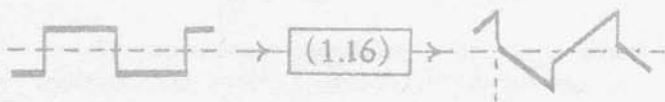

When a resistance  $R_o$  is added to the feedback capacitor of the Integrator (1.8), the circuit will transmit the input signal modified by the addition of the time integral of the input.

This circuit has applications in closed loops to provide a proportional plus reset control action.

1.17

AUGMENTING DIFFERENTIATOR

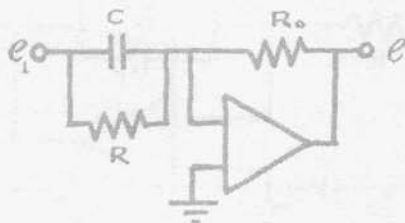

$$-\frac{e}{e_1} = \frac{R_o}{R} (1 + T_p)$$

$$T = RC$$

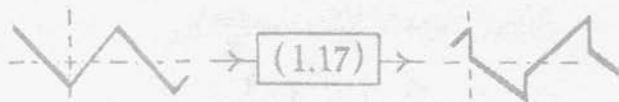

Placing a resistor  $R$  in shunt with the input capacitor of circuit (1.11) permits the transmission of the input signal augmented by the time derivative of the input.

One or more of these networks in sequence will permit prediction operations on a voltage signal useful for automatic control and other instrumental actions. In particular this circuit in tandem with circuit (1.16) will provide standard three term (PID) control operations.



## II...Circuits with Both Inputs Active

### 2.0 USE of DIFFERENTIAL INPUTS

The availability of balanced differential inputs in Philbrick Operational Amplifiers makes possible many useful circuits and applications, a few of which are indicated in this section. Several others of a more specialized variety are indicated in Section IV.

It is of interest and importance to note that both inputs to the amplifier may vary in common through a range of approximately  $\pm 50V$  (for both K2-W and K2-X).

### 2.1 VOLTAGE FOLLOWER

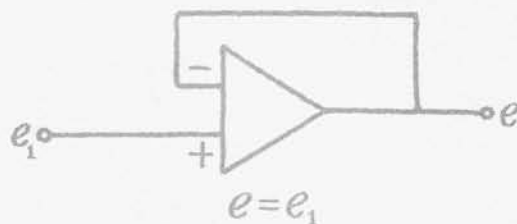

The simplest use of the positive input for a variable signal,  $e_1$ , is as a voltage reproducer or *follower*. Here the output,  $e$ , is fed back into the negative input as degenerative feedback at high gain.

Such a follower has negligible attenuation or phase distortion, with an input impedance of more than 100 megohms and an output impedance of less than one ohm.

This gives a follower, ideal for isolating and driving computing and measuring circuits, as well as for direct signal detection at low energy sources in recording and control applications.

### 2.2 DIRECT ADDER

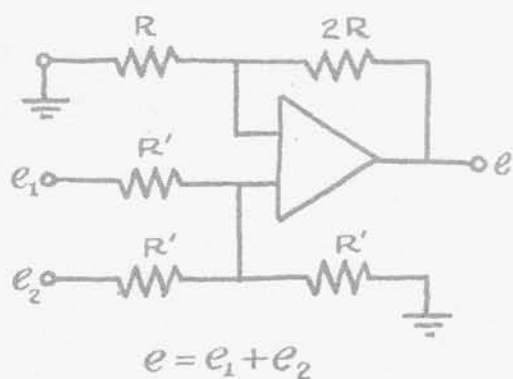

An example of advantageous use of both inputs is afforded by the circuit shown. The output,  $e$ , is the direct, positive sum of the two inputs,  $e_1$ , and  $e_2$ .

By altering the values of the resistances, scale changes and weighting factors are made possible.

### 2.3 SUBTRACTOR

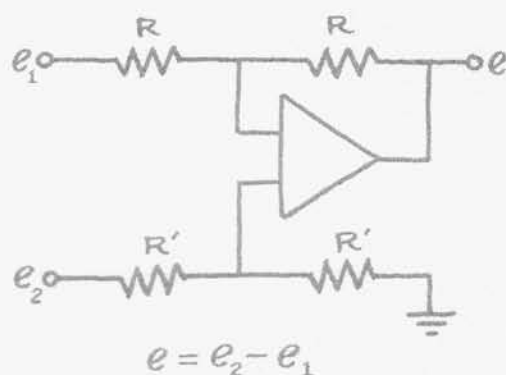

A modification of Circuit (2.2) permits direct subtracting operations. The input signal,  $e_1$ , is thus inverted and deducted from the other input,  $e_2$ .

# II...Circuits with Both Inputs Active (continued)

## 2.4 ADDER-SUBTRACTOR

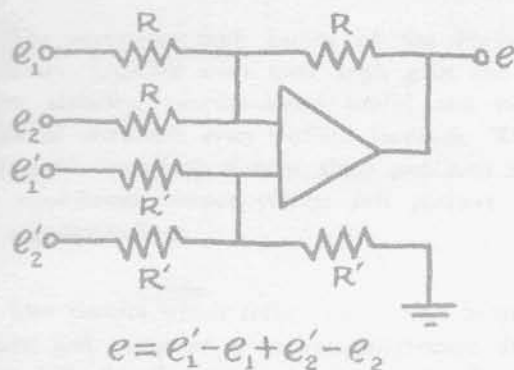

This circuit is an obvious combination and generalisation of Circuits (2.2) and (2.3). It may, of course, be extended to any number of input signals and can provide scale changes and weighting factors. However, note that unused inputs should be grounded (to preserve scale).

By using potentiometers, ganged or otherwise, linear combiners similar to Circuit (1.6) can be constructed following the above principles. Circuit (2.6) below may offer some suggestion.

## 2.5 DIFFERENTIAL INTEGRATOR

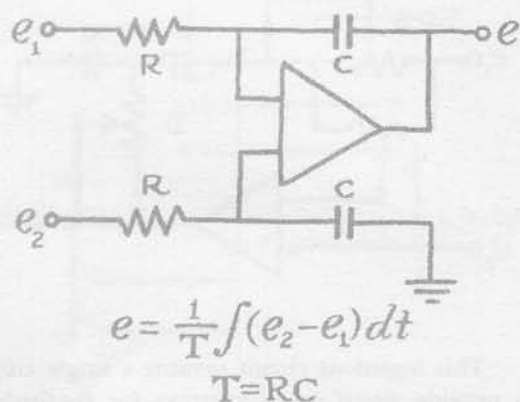

By replacing the feedback and grounding resistances of Circuit (2.3) by capacitors, a useful form of differential or subtracting integrator can be fashioned, which is of inestimable value in measurement, simulation and control of systems of all kinds.

Observe also that the same principle can be applied to a multiplicity of inputs, using the ideas of Circuit (2.4).

## 2.6 POSITIVE-NEGATIVE SCALER

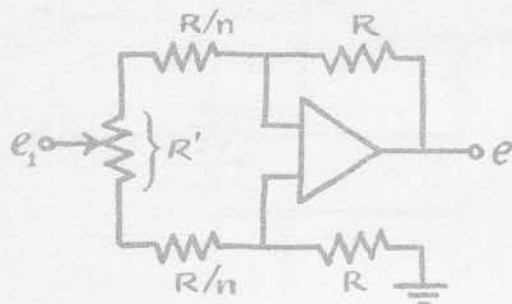

By driving the two inputs of the Subtractor (2.3) from a potentiometer, a variable gain device is produced which has certain advantages, particularly for empirical adjustments requiring a small range of gain each side of zero.

More articulate potentiometer arrangements make feasible simple direct calibration.

## 2.7 ADJUSTABLE LAG

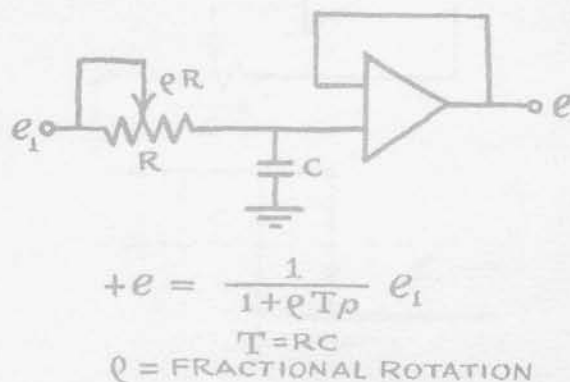

A non-inverting first order lag with low distortion and without attenuation is provided by this positive input application.

The principal advantage of this arrangement lies in the linear calibration of the adjusting potentiometer.

## II...Circuits with Both Inputs Active (continued)

2.8

### CONTROLLER MECHANISM

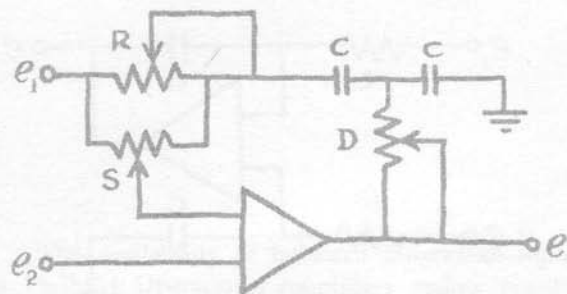

This ingenious circuit permits a single amplifier to provide signal transformation for feedback control of a measured variable, in the form of a scaled voltage  $e_2$ , arising in any manufacturing process guidance system, and the like.

The input  $e_2$  is compared to a set point or reference input  $e_1$ , and the resulting error signal is amplified and fed back so that the output voltage can serve as the command to the manipulated variable. The feedback network provides "three-term" (PID) control action with adjustments for Reset at  $R$ , Sensitivity at  $S$  and Derivative at  $D$ .

# III . . . Limit-to-Limit and Multivibrator Applications

## 3.0 DIFFERENTIAL INPUTS

The access to both inputs of the Philbrick amplifiers, together with their high gain and inherent stability, permits many useful and novel modes of operation even without feedback. When used in this open-loop manner, these amplifiers have two equilibrium output values: full positive and full negative voltage.

The circuits which follow utilize this bi-stable feature and comprise a logical progression from simple "flip-flops" to more intricate multivibrators.

Applications abound for such operations in industrial and scientific instrumentation, computation and control.

## 3.1 VOLTAGE CROSSING DETECTOR

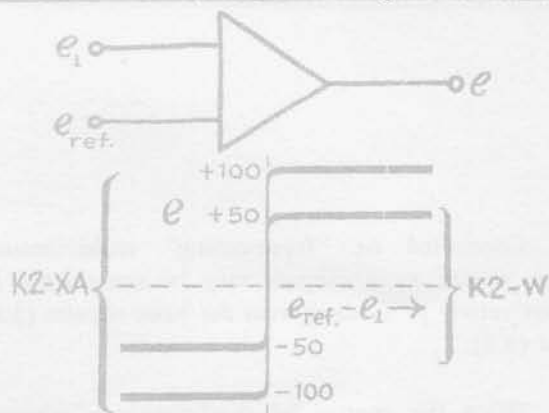

The operational amplifier, by itself, serves as a sensitive voltage detector. When the input voltage,  $e_1$ , changes but a few millivolts up or down from a fixed or variable reference voltage,  $e_{ref}$ , the output,  $e$ , will swing from either  $-100$  vdc fully loaded to  $+100$  vdc (for the K2-XA) or  $-50$  to  $+50$  vdc fully loaded (for the K2-W). If  $e_{ref}$  is zero, one thus obtains a "flip-flop" or two-position contractor.

Other narrower but adjustable limits may be imposed on output voltage swings through use of Selector Circuits (4.3) or by Bounding as in Circuit (4.5).

## 3.2 DETECTOR with HYSTERESIS

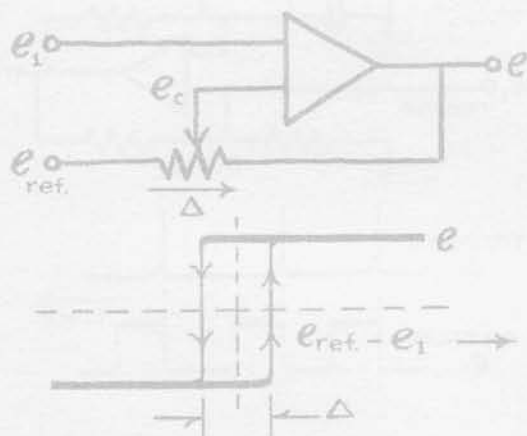

The addition of a potentiometer (or fixed resistances) connecting the output back to the reference, provides a two-valued control voltage,  $e_c$ , to the operational amplifier. When the output,  $e$ , is full positive, the control,  $e_c$ , is higher than when  $e$  is full negative. This shift in effective reference introduces hysteresis or "free-play", in an amount proportional to potentiometer drop  $\Delta$ .

## 3.3 CONTACTOR with HYSTERESIS

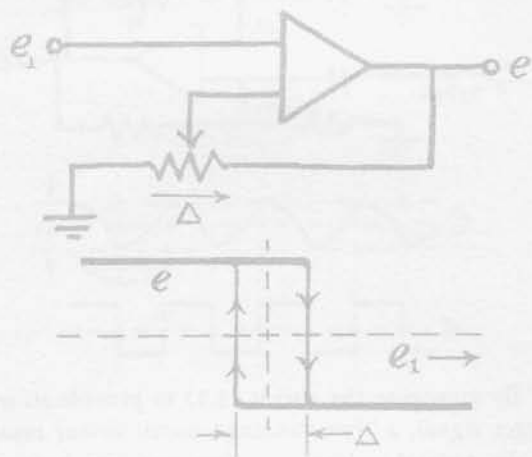

Here the reference voltage,  $e_{ref}$ , of circuit (3.2) is grounded. The performance is identical in character, but now the device becomes a simple hysteretic contactor, extremely useful for control and instrumentation purposes, where stable, two-position operation is desired. The value of  $\Delta$  in these applications often becomes a necessary or desirable control parameter.

# III . . . Limit-to-Limit and Multivibrator Applications (continued)

## 3.4 MULTIVIBRATORS

Controlled or "free-running" multivibrators with square wave outputs may be constructed in great variety proceeding from the basic circuits (3.2) and (3.3).

Often the control or synchronizing "trigger" signals will be in the form of short-duration pulses. For such cases hysteresis is essential to prevent premature return or reversal of the output, as well as to provide variable threshold effects.

## 3.5 BI-STABLE MULTIVIBRATOR

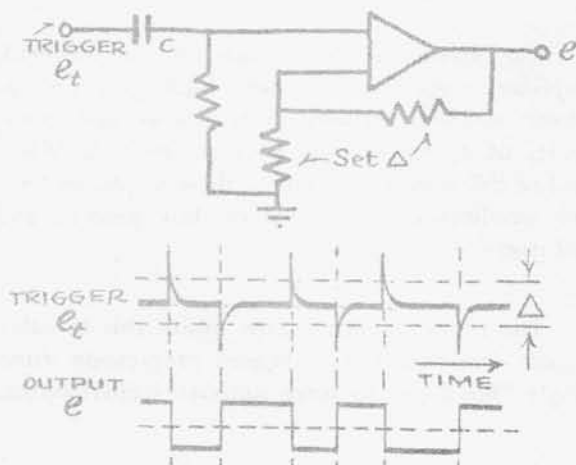

If the circuit (3.3) is ac coupled to a pulsed trigger voltage, a bistable controlled multivibrator results. In the absence of trigger pulses the output will remain in its last state. But upon receipt of a positive pulse, the output will swing full negative and vice versa. By varying the value of the threshold,  $\Delta$ , the circuit can be selective with respect to pulse height.

If the sync source has low impedance, bandwidth is increased by providing a shunt capacitance from output to positive input.

## 3.6 ASTABLE MULTIVIBRATOR

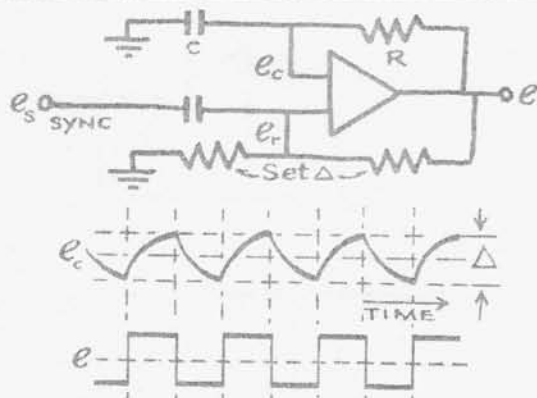

By arranging the circuit (3.5) to provide its own trigger signal, a "free-running" multivibrator results. As the control voltage,  $e_c$ , rises past the hysteretic reference,  $e_r$ , the output drops abruptly to its negative value, causing  $e_c$  to begin to drop. This sequence is then repeated alternately negative and positive. Provision of the sync input allows the oscillator to be locked into phase with any other signal.

The period depends jointly on the charging time,  $RC$ , and threshold,  $\Delta$ . Providing an integrator between  $e$  and  $e_c$ , with the latter supplied to a follower, a very precise triangular wave generator results.

## 3.7 MONOSTABLE MULTIVIBRATOR

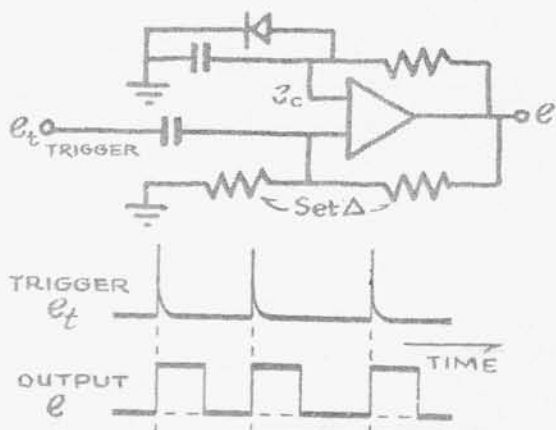

This circuit is identical to (3.6) except that a diode has been shunted across the capacitor permitting  $e_c$  to vary in only one direction with respect to ground and resulting in a "single shot" multivibrator. Thus for the direction shown, a positive trigger will produce positive pulses, whose duration, as before, depends on  $RC$  and  $\Delta$ . The polarity may be reversed by reversing the diode and using negative pulses.

Better wave forms will generally result if thermionic diodes are used.

# III . . . Limit-to-Limit and Multivibrator Applications (continued)

3.8

## PULSE-TIME MODULATOR

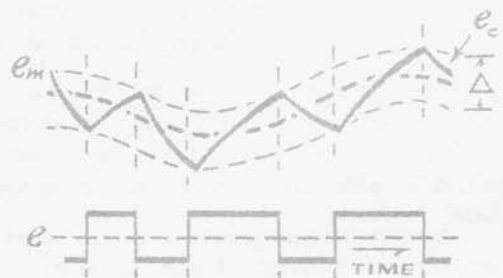
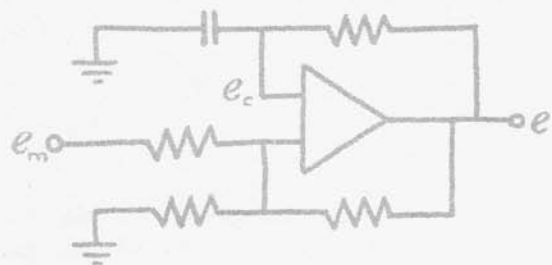

This circuit is a simple extension of (3.6) which biases the threshold level off zero in response to a modulating signal,  $e_m$ , and can be used either as a means of time modulation ( $e_m$  variable) or as an asymmetric generator ( $e_m$  fixed).

# IV ... Nonlinear and Other Special Circuits

4.0

## GENERAL

Unlimited varieties of special purpose components may be fabricated by employing linear or nonlinear networks connected to one or both inputs of an operational amplifier.

Linear variants of this genus may be synthesized intuitively or through rationale aided by tables of transfer impedances such as those found in the *Palimpsest* based on an earlier table of McCoy.

However, by gracious use of nonlinearity, many other useful functional operators may be realized. Some suggestions follow.

4.1

## ABSOLUTE VALUE

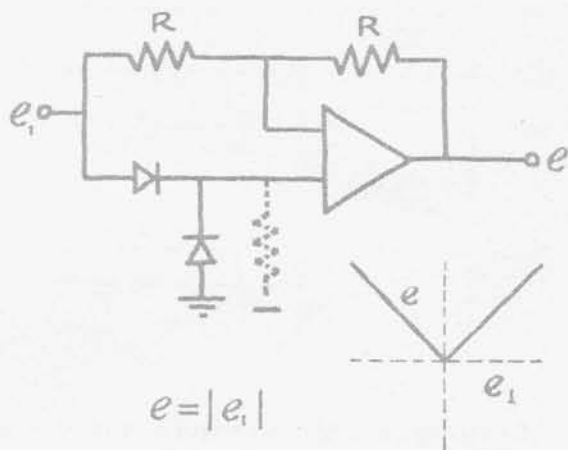

The circuit shown produces the absolute value of the input. Whenever the input is negative, the reference is grounded and a conventional inverting amplifier follows. But positive values of  $e_1$  cause the reference to be connected directly to the input, and converts the circuit to a voltage follower.

4.2

## PEAK FOLLOWER

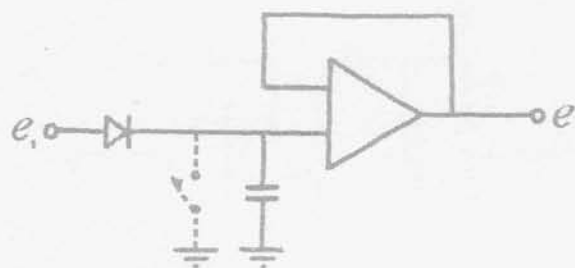

This circuit consisting of a diode connected so that a condenser may be charged but not readily discharged, when driven by a load impedance source and followed by an amplifier used as a voltage reproducer, will provide an output voltage which is the peak value over a past history of the input. This epoch may be varied through manipulation of the size and discharge conditions of the capacitor (i.e. shunt resistance or switch).

4.3

## SELECTOR CIRCUITS

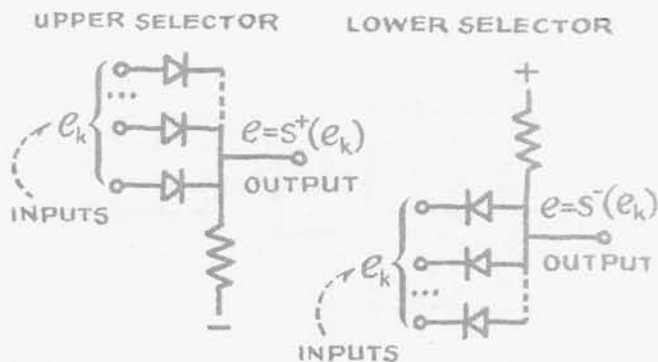

In mathematical analysis or number theory, the circuit on the left gives the *least upper bound* (l.u.b.) of the inputs while that on the right yields the *greatest lower bound* (g.l.b.). In terms of time variations, these two operators yield the *upper* and *lower envelopes*, respectively, of a multiplicity of inputs.

These simple logical concepts reduced to practice have innumerable applications, some few of which are indicated in panels to follow.

# IV ... Nonlinear and Other Special Circuits (continued)

4.4

## DWELL CIRCUIT

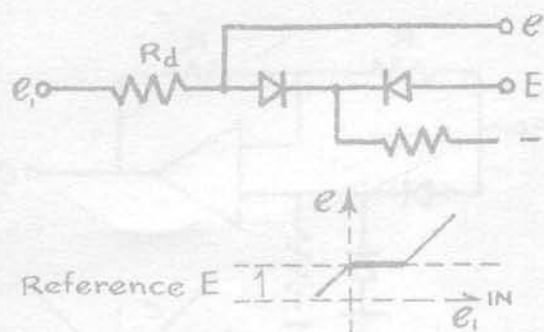

By driving one side of an Upper Selector through a dropping resistor  $R_d$  and taking as output the voltage at the opposite side, a controlled dwell voltage may be impressed at a voltage level determined by  $E$ . This circuit has many modulation applications besides its direct use as a nonlinear operator for circuits such as (4.6) and (4.7) below.

4.5

## CLIPPING or LIMITING

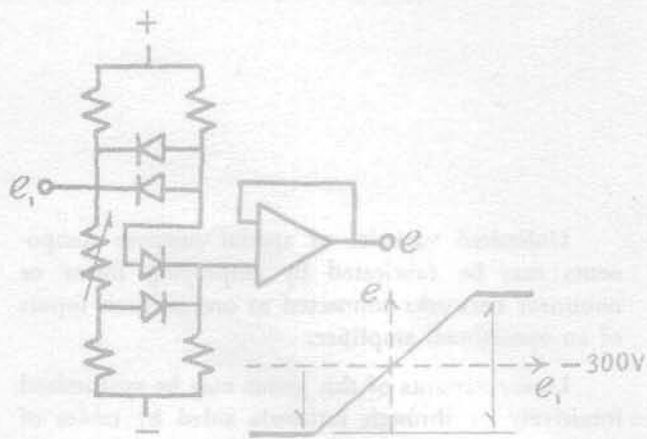

A Lower Selection between a signal  $e_i$  and a fixed positive voltage followed by an Upper Selection between the result and a fixed negative voltage will result in the bounding of a signal between these fixed constraints. The circuit shown provides a low impedance output  $e$  with equal and opposite fixed limits controlled by the potentiometer.

Supplying bounds modulated by a second input results in a low cost modulator multiplier.

4.6

## THRESHOLD or DEAD ZONE

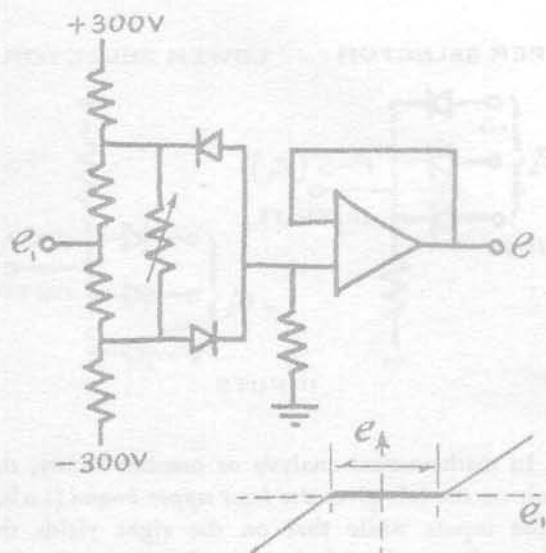

This application of the Dwell Circuit (4.4) will yield a device providing a fixed but adjustable inert zone within which an input signal  $e_i$  results in a zero output signal  $e$ . Outside this threshold, response will follow stimulus.

4.7

## BACKLASH or HYSTERESIS

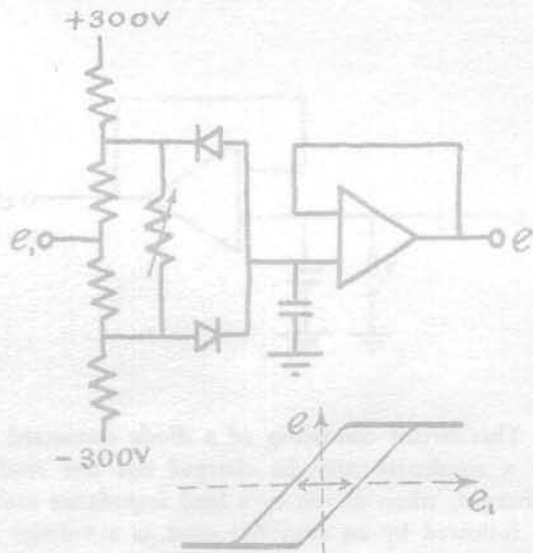

If a small Capacitor replaces the shunt resistor of the previous circuit, an adjustable hysteretic effect will result. This yields the response associated with free play or loose joints in gears or linkages, as well as similar phenomena in biomechanics and physics.



# IV ... Nonlinear and Other Special Circuits (continued)

4.8

POWER LAWS

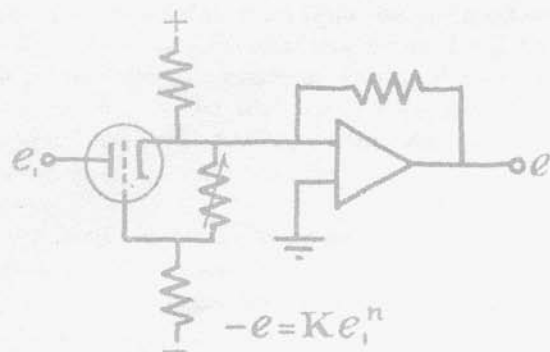

The plate currents of certain triodes (such as Tung-Sol 12AU7) vary closely with a constant power of plate voltage for a fixed grid voltage, and over a restricted range. This nonlinear resistor may be used in the input path of an operational amplifier to provide powers between 1.5 and 11.

If the input is first rectified by circuit (4.1), a tolerable Square Law may be obtained in this way.

4.9

ROOT LAWS

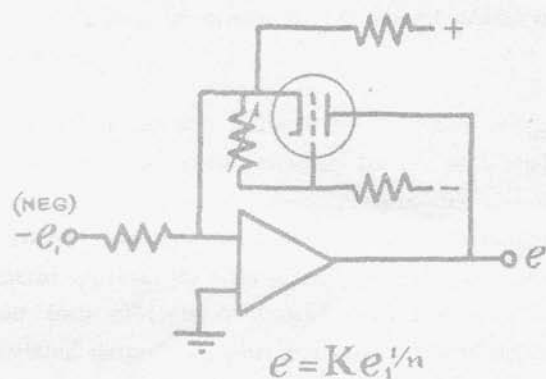

By placing the suitably biased triode of the previous panel in the feedback path, a given Root Law may be obtained over similar excursions and ranges of exponent.

Suitable arrangements of Selector Circuits or similar triodes parallel-opposing will afford *even* and *odd* root laws of corresponding orders.

# G...Computing Auxiliaries and Accessories

## G.1 GENERAL

The previous sections have dealt with the nature and uses of GAP/R Plug-in Amplifiers and the circuits that transform them into useful computing devices. However some attention should be given to the power source necessary to activate these components as well as the specifications for circuit components and the hardware for mounting and packaging.

A well regulated power supply of low output impedance is a prime necessity to realize the full potential of Philbrick Amplifiers and to insure maximum accuracy. Equipment to satisfy this need is further described in the adjacent panel.

Many laboratories and computing centers have constructed instruments and computers around standard GAP/R Plug-in Amplifiers using available technicians and materials. However, for large installations (or overburdened staffs) it has proved economically advantageous to utilize many other packages manufactured by Philbrick. These include manifolds and chassis, as well as kits for rapid assembly of passive computing elements and selected lists of resistors, capacitors and diodes. All of these are commented upon infra.

## G.3 CHASSIS and MANIFOLDS

Philbrick has a number of modular packages available as receptacles for the Computing Amplifiers with biasing and supply circuitry provided internally and with computing connections readily available at the front. A logical arrangement of jacks enables direct synthesis of computing networks of infinite variety.

For example the Model 6009 Operational Manifold, containing a row of octal-sockets for 10 K2-Ws, is a typical unit in this category. It has a bias control at each computing station which provides sensitive and stable adjustment of the voltage difference between positive and negative inputs. Uniform  $\frac{3}{4}$ " spacing at all computing connections allows use of standard General Radio type banana plugs for rapid circuit arrangement.

## G.2 POWER SUPPLIES

Philbrick offers regulated supplies ranging from 100 to 500 milliamperes at  $\pm 300$  volts output. About 20 K2-Ws may be driven by the lowest priced unit in this line.

GAP/R's Model R-100B is a new and compact power supply designed primarily for use with analog computing instruments. However, its modest cost and excellent performance has resulted in widespread general application. This supply may be conveniently built into cabinets or quickly rack-mounted. The regulated outputs are plus and minus 300 VDC, each producing a conservative 100 Milliamperes.

A rack mounting supply, the Model R-300 is a 300 milliampere version at a higher price.

For still larger installations the Model R-500 Regulated Power Supply is a deluxe supply having an output of  $\pm 300$  volts, 500 milliamperes maximum.

Bulletins are available on all above mentioned power supplies, as well as others.

## G.4 MODULAR ASSEMBLIES

Simple temporary lash-ups are always possible with a few computing elements, plus plugs and alligator clips. However, when fairly permanent circuit assemblies are found desirable it is convenient to mount the circuit components in suitable structures which will preserve form, yet permit flexible use of amplifiers.

Accordingly, many *standard* plug-in elements are available for rapid exploitation of GAP/R Manifolds, freeing valuable personnel to spend time more advantageously directly in computation and research.

One of the most popular arrangements is in kit form and is designated Model K- Modular Assembly Unit. Included are pre-drilled Bakelite panels (dimensionally accurate) that fasten together like a "Meccano" set. These panels (front, back, top and bottom) have positioned holes for the reception of jack plugs, potentiometers, switches and banana plugs. The assembly blocks are pre-tapped and designed for single and multiple assembly.

Pre-drilled, insulated plug-boards may be had in single, double and up to ten-module units.

Banana plugs and jacks for circuit connections are a commercially available item.

Prices and information on any of the above items are available on request.

# G...Computing Auxiliaries and Accessories (continued)

G.5

## CIRCUIT COMPONENTS

With the rigorous demands of amplifier circuitry already taken care of in GAP/R Plug-in Computing Amplifiers and Manifolds, the user is in a position to get directly at the problems of calculation and simulation.

A selected assortment of circuit elements plus banana plugs and signal cords are all that are needed to obtain results readable on a voltmeter, recording oscillograph or cathode-ray oscilloscope.

Representative circuit elements, suggested for GAP/R Operational equipment follow:

Resistors (Deposited Carbon);

50K, 100K, 200K, 250K, 750K, 1 Meg., 1/2%

Capacitors (Silver Mica);

400 MMF, 4000  $\mu\mu\text{F}$ , 1%

Capacitors (Mylar)

0.04 MF, 0.4 MF, 1.0  $\mu\text{F}$ , 1%

Variable Resistors (wire wound)

Clarostat Type 10, 100K

These items are available to users of Philbrick equipment; prices are furnished on request.

G.6

## PASSIVE PLUG-INS

Another group of elements provided in module form for wide use among GAP/R Computer users are the "K1 Passive Operational Plug-ins". Assembled from units of the "K1 kits" they are all ready to *plug-in*. Here again, where time is an important factor, these units in pre-assembled form afford rapid utilization of the computing elements. Brief descriptions of some of the standard units follow.

Model K1-A *Adder* has five adding positions and sum output. All resistors are 500K, 1/2%.

Model K1-C *Coefficient* uses a 100K, wire wound potentiometer, plus input and output jacks.

Model K1-D *Differentiator* has a three-position selector switch for time factors, plus input and output jacks.

Model K1-J *Integrator* has the inverse action of the K-D with similar switchable internal capacitors.

Model K1-L *Unit-lag* incorporates a 100K, wire wound potentiometer, a two-position capacitor selector switch and input and output jacks.

Multiplying modules and many other operations have also been pre-assembled by GAP/R.

For further information, write for Bulletin on GAP/R "K1 Passive Plug-Ins."