

1.	SPECIFICATIONS	3
2.	FRONT PANEL	4
3.	ASSEMBLY DESCRIPTION	5
	3-1 Keyboard Unit Assembly KB-1	5
	3-2 Control Unit Assembly CU-1	5
	3-3 Sub Chassis Unit Assembly SU-1	7
	3-4 Power Supply Unit Assembly PC-5	7
4.	GENERAL CAUTIONS	8
5.	GENERAL BLOCK DIAGRAM	9
6.	CABINET DISASSEMBLY	10
7.	WIRING BLOCK DIAGRAM	11
8.	KEYBOARD UNIT ASSEMBLY KB-1	11
	8-1 Keyboard Assembly SK-142B	11
	8-2 Bender Assembly PB-1	11
	8-3 Control Unit Assembly CU-2	12
	8-4 Manual Board Assembly OP-25	12
	8-5 Circuit Diagram KB-1	13
9.	CONTROL UNIT ASSEMBLY CU-1	14
	9-1 Circuit Diagram CU-1	16
	9-2 Circuit Board Assembly OP-19	18
	9-3 Circuit Diagram OP-19 ($\pm 10V$, Phones, LFO-1, LFO-2, S/H, Noise Gen.)	19
	9-4 VCO Board Assembly VO-3	20
	9-5 Circuit Diagram VO-3 (VCO-1)	21
	9-6 Circuit Board Assembly OP-20	22
	9-7 Circuit Diagram OP-20 (VCO-2, Ring Mod)	23
	9-8 Mixer Board Assembly OP-23	24
	9-9 Circuit Diagram OP-23 (Mixer, Ext. Amp.)	25
	9-10 Circuit Board Assembly OP-21	26
	9-11 Circuit Diagram OP-21 (VCF, VCA, BPF)	27
	9-12 Circuit Board Assembly OP-22	28
	9-13 Circuit Diagram OP-22 (AR, ADSR, Fixed Env. Lamp.)	29
10.	SUB CHASSIS UNIT ASSEMBLY SU-1	30
	10-1 Circuit Diagram SU-1	31
11.	POWER SUPPLY UNIT ASSEMBLY PC-5	32
	11-1 Circuit Diagram PC-5	32
	11-2 Power Supply Board Assembly PS-17	33
	11-3 Power Supply Board Assembly PS-23	33

12. ADJUSTMENT	34
12-1 PS-17, PS-23	34
12-1-1 +14V, -14V	34
12-2 OP-19	34
12-2-1 +10V, -10V	34
12-2-2 LFO-1	34
12-2-3 SAMPLE & HOLD	35
12-2-4 NOISE, GENERATOR	36
12-3 KB-1	36
12-3-1 KEY VOLTAGE	36
12-3-2 BENDER VOLTAGE	37
12-4 VO-3	37
12-4-1 VCO RANGE SET	37
12-4-2 VCO-1	37
12-4-3 VCO-1	38
12-4-4 VCO-1 FREQUENCY WIDTH	38
12-4-5 VCO-1 FREQUENCY ADJUSTMENT	41
12-5 OP-20	41
12-5-1 VCO-2	41
12-5-2 VCO-2	41
12-5-3 VCO-2 FREQUENCY WIDTH	42
12-5-4 VCO-2 FREQUENCY ADJUSTMENT	42
12-5-5 RING MOD	43
12-6 OP-21	44
12-6-1 VCA	44
12-6-2 VCF	45
12-7 OP-22	48
12-7-1 ADSR	48
13. PARTS LIST	49
13-1 OP-25	49
13-2 OP-19	49
13-3 VO-3	50
13-4 OP-20	51
13-5 OP-23	52
13-6 OP-21	52
13-7 OP-22	53
13-8 PS-17	53
13-9 PS-23	54

2. FRONT PANEL



3. DESCRIPTION OF ASSEMBLIES

The MODEL SH-5 consists of 4 main units shown below in order of disassembly procedure.

- | | |
|-------------------------------|------|
| 1) KEYBOARD UNIT ASSEMBLY | KB-1 |
| 2) CONTROL UNIT ASSEMBLY | CU-1 |
| 3) SUB CHASSIS UNIT ASSEMBLY | SU-1 |
| 4) POWER SUPPLY UNIT ASSEMBLY | PC-5 |

3-1. KEYBOARD UNIT ASSEMBLY KB-1

This unit is subdivided into smaller blocks:

- | | |
|--------------------------|---------|
| 1) KEYBOARD ASSEMBLY | SK-142B |
| 2) CONTROL UNIT ASSEMBLY | CU-2 |
| MANUAL BOARD ASSEMBLY | OP-25 |
| BENDER ASSEMBLY | PB-1 |

A. Keyboard Circuit

Consists of a constant current source fed to the keyboard resistors which provides specific voltage drops when keyboard keys are pressed.

This voltage is fed to an S & H Circuit where it is held until another voltage is produced by depressing another key.

The output of this circuit is used for controlling the VCO's and VCF.

A second circuit generates trigger-pulses by means of the ON-OFF manuals under the keys for control of triggering LFO-1, LFO-2, S/H, and ENV GEN.

B. TUNING, TRANSPOSE, PORTAMENTO

Each controls 2 VCO's simultaneously.

C. BENDER

The voltage output is variable from + to -, and the circuit is for the control of VCO's or VCF, selected with a switch.

In the VCO mode, there are further selections of 3 ranges: SEMI - WHOLE - QUINT.

Setting the slide switch on VCF, the starting tone color of the bender effect can be changed by moving the CUT-OFF FREQ. control in the VCF section.

3-2. CONTROL UNIT ASSEMBLY CU-1

Subdivided as follows:

- | | |
|---------------------------|-------|
| 1) CIRCUIT BOARD ASSEMBLY | OP-19 |
| 2) VCO BOARD ASSEMBLY | VO-3 |
| 3) CIRCUIT BOARD ASSEMBLY | OP-20 |
| 4) MIXER BOARD ASSEMBLY | OP-23 |
| 5) CIRCUIT BOARD ASSEMBLY | OP-21 |
| 6) CIRCUIT BOARD ASSEMBLY | OP-22 |

3-2-1. CIRCUIT BOARD ASSEMBLY OP-19

Contains: $\pm 10V$ Regulator, PHONES, LFO-1, LFO-2, S/H, and NOISE GEN, circuits.

A. $\pm 10V$ Regulator

The constant voltages +14V and -14V of the input are converted into highly stable D.C outputs: +10.00V and -10.00V.

Generally speaking, the more accurate the adjustment (the more zeroes after the decimal point) the more accurate the VCO tracking will be.

B. PHONES

Controls the LEVEL without any relation to the OUTPUT LEVEL of VCA.

C. LFO-1



This is a Low Frequency Oscillator to produce both inverted and non-inverted Sawtooth waveforms with a phase difference of 180° .

D. LFO-2

Produces Sine wave, Square wave (inverted and non-inverted), and Triangular wave for use in modulation, and TRIG. for AR. and ADSR.

DELAY TIME utilizes Sine wave alone.

E. S/H

This circuit is for sampling voltages from different waveforms, using LFO-1 (), LFO-2 (), and RANDOM (NOISE) for its input source. The output can be used to control VCO-1 and the VCF for getting special effects.

Sample time decides the timing of the sampling operation.

Lag time uses an RC filter to add lag to quick voltage changes.

F. NOISE GEN.

The sound source here is the white noise produced at the B-E (base - emitter) junction of a reverse biased transistor.

It is amplified and, through filtering, is changed to either WHITE or PINK at the output.

3-2-2. VCO BOARD ASSEMBLY

VCO-1

A VCO is an oscillator whose frequency is controlled by a control voltage coming from the Keyboard or other external sources.

Incoming linear control voltages are first converted into voltages with an exponential increasing ratio.

The oscillator itself is a sawtooth generator. Wave shapers convert this sawtooth to triangle and square waves.

This assembly functions as VCO-1, and is capable of synchronous driving of VCO-2 by means of the synchronizing pulses generated in this assembly.

3-2-3. CIRCUIT BOARD ASSEMBLY OP-20**VCO-2, RING MOD.**

VCO-2 is an oscillator which is about the same as VCO-1.

With the Keyfollower turned to OFF, the frequencies generated here are held at a constant level and not subject to follow the keyboard.

RING MOD. (ring modulator) is a circuit for producing sounds of special effect, such as bell-like sounds. The sum and difference of the two input frequencies are the only frequencies to appear at the output of the ring modulator.

3-2-4. MIXER BOARD ASSEMBLY OP-23

This is the section that decides where the signals coming from NOISE GEN., VCO-1, VCO-2, RING MOD., EXT. IN. will go.

Also provided here is an amplifier circuit for the signals of EXT. IN.

3-2-5. CIRCUIT BOARD ASSEMBLY OP-21**VCF, BAND PASS FILTER, VCA**

The VCF is a Voltage Controlled Filter and can be used either as: LPF, BPF, and HPF.

The LPF consists of a ladder type network of diode chain transistors, and is capable of generating by itself frequencies of a wide range so that it can be used to make musical scales following the keyboard manuals.

Band Pass Filter is, unlike the others, a fixed filter and not voltage controlled.

The VCA has its gain under control of the control voltage applied to the base of the current source transistor in this circuit.

3-2-6. CIRCUIT BOARD ASSEMBLY OP-22**AR, ADSR, FIXED ENV.**

The Envelope Generators have separate controls for controlling the elements of the envelopes (ATTACK and RELEASE for the AR, and ATTACK, DECAY, SUSTAIN, and RELEASE for the ADSR). The Envelope Generators are triggered from the Keyboard Circuit gate pulses or from LFO-2, S/H, or EXT.

The FIXED ENV, however, is triggered only by the keyboard gate pulse.

3-3. SUB CHASSIS UNIT ASSEMBLY SU-1 (Including Pack Assembly BX-13)

Located here are the output jacks of SH-5, also with jacks for control from external sources.

3-4. POWER SUPPLY UNIT ASSEMBLY PC-5

This is to produce the regulated $\pm 14V$ and in order to secure voltage accuracy, potentiometers are provided in this circuit.

Note that PS-17 is for 100 – 120V, while PS-23 is for 200 – 250V.

1976-10-30 SH-5

4. GENERAL CAUTIONS

4-1. Fuses

When replacing fuses, use only those rated as shown on the caution label on the circuit board.

Repeatedly blown fuses indicate something wrong with the circuits. Using larger value fuses will only aggravate this condition and will result in damage to the circuits.

4-2. Adjustment

Calibration adjustments should be done in the order given.

Accurate adjustment can be assured only if the procedures are followed exactly as given.

4-3. Slide Switch

Double check the positions of slide switches.

Slide switches set in between positions is the largest cause of malfunction of this synthesizer.

4-4. Replacement of parts

Use only those as specified in the Parts List.

Use of parts other than as specified can cause function instability or circuit damage.

5. GENERAL BLOCK DIAGRAM

1976-10-30 SH-5

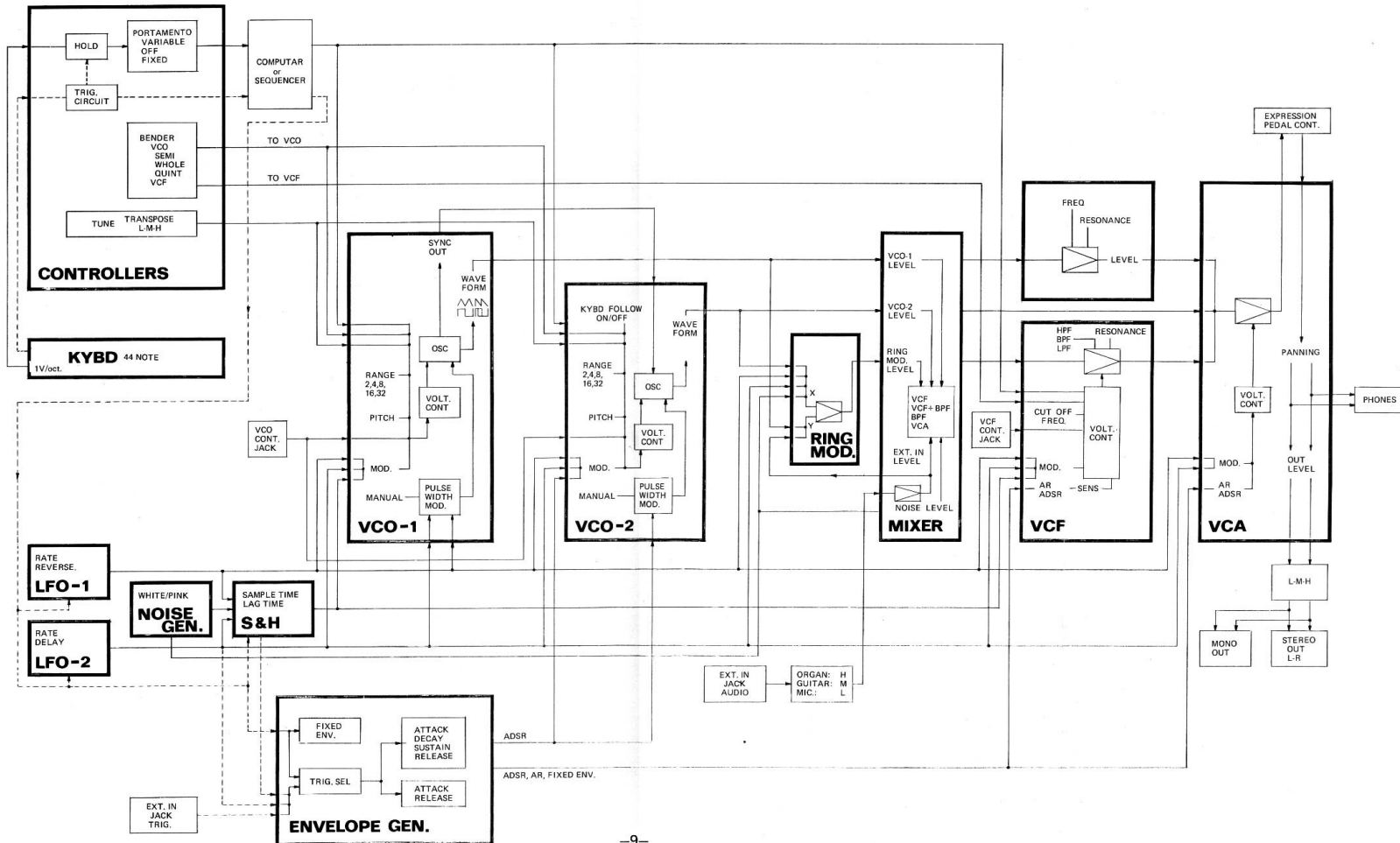

6. CABINET DISASSEMBLY

Fig. 1

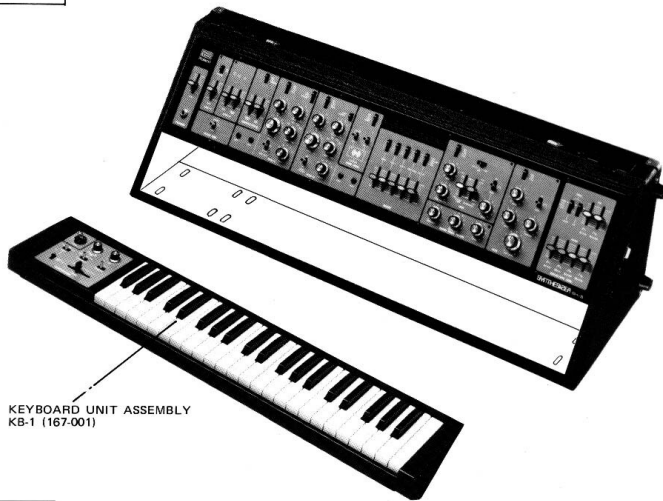

Fig. 2

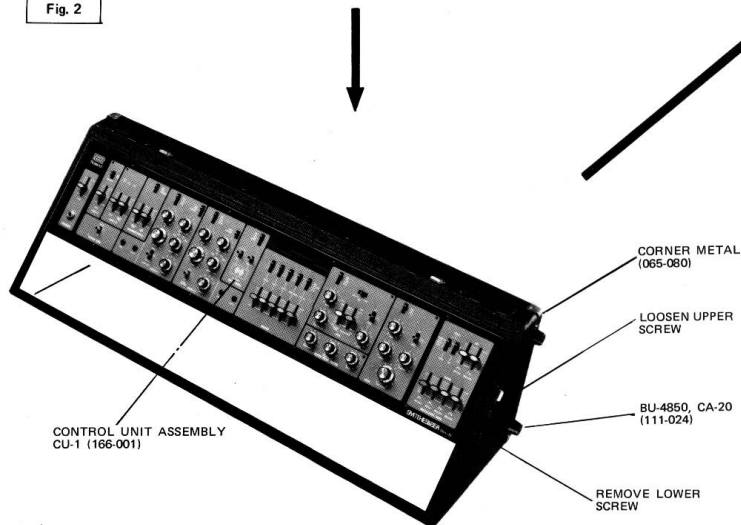

Fig. 3

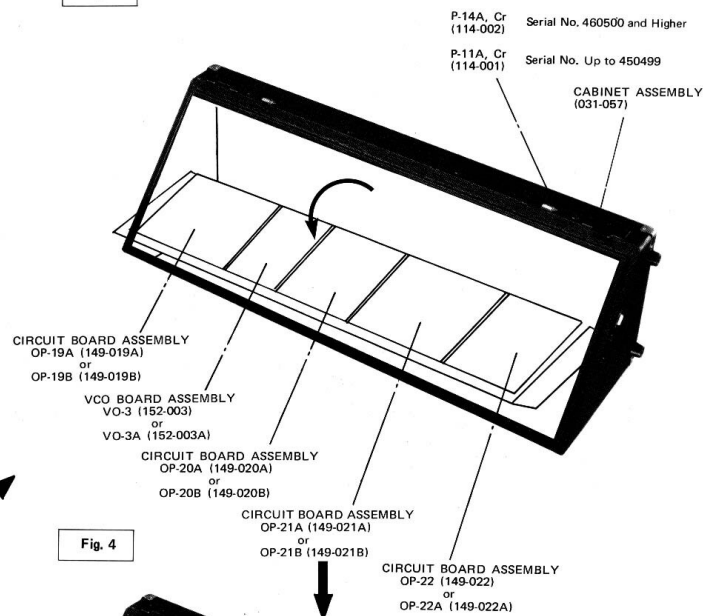

Fig. 4

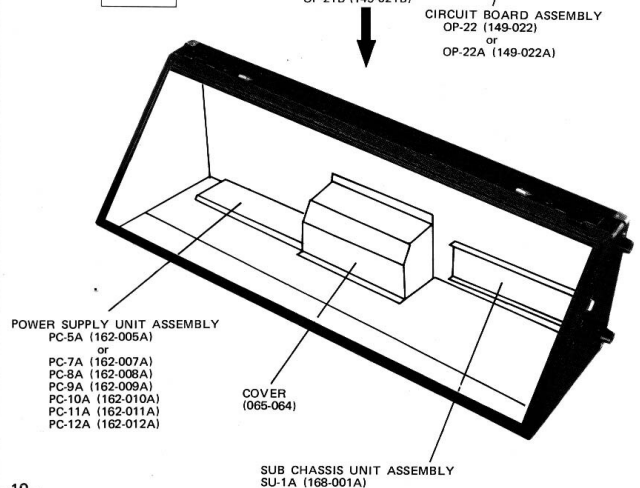
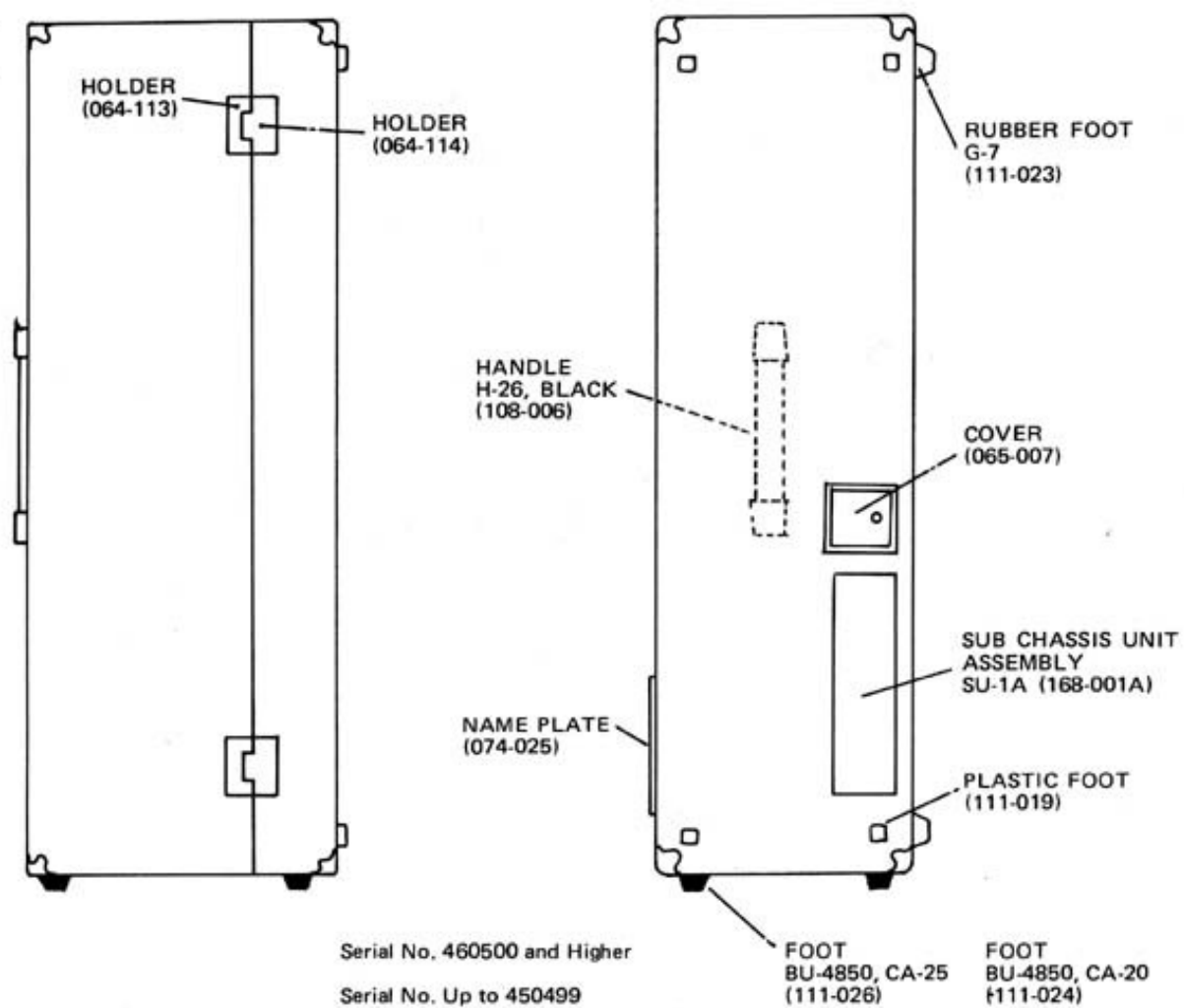
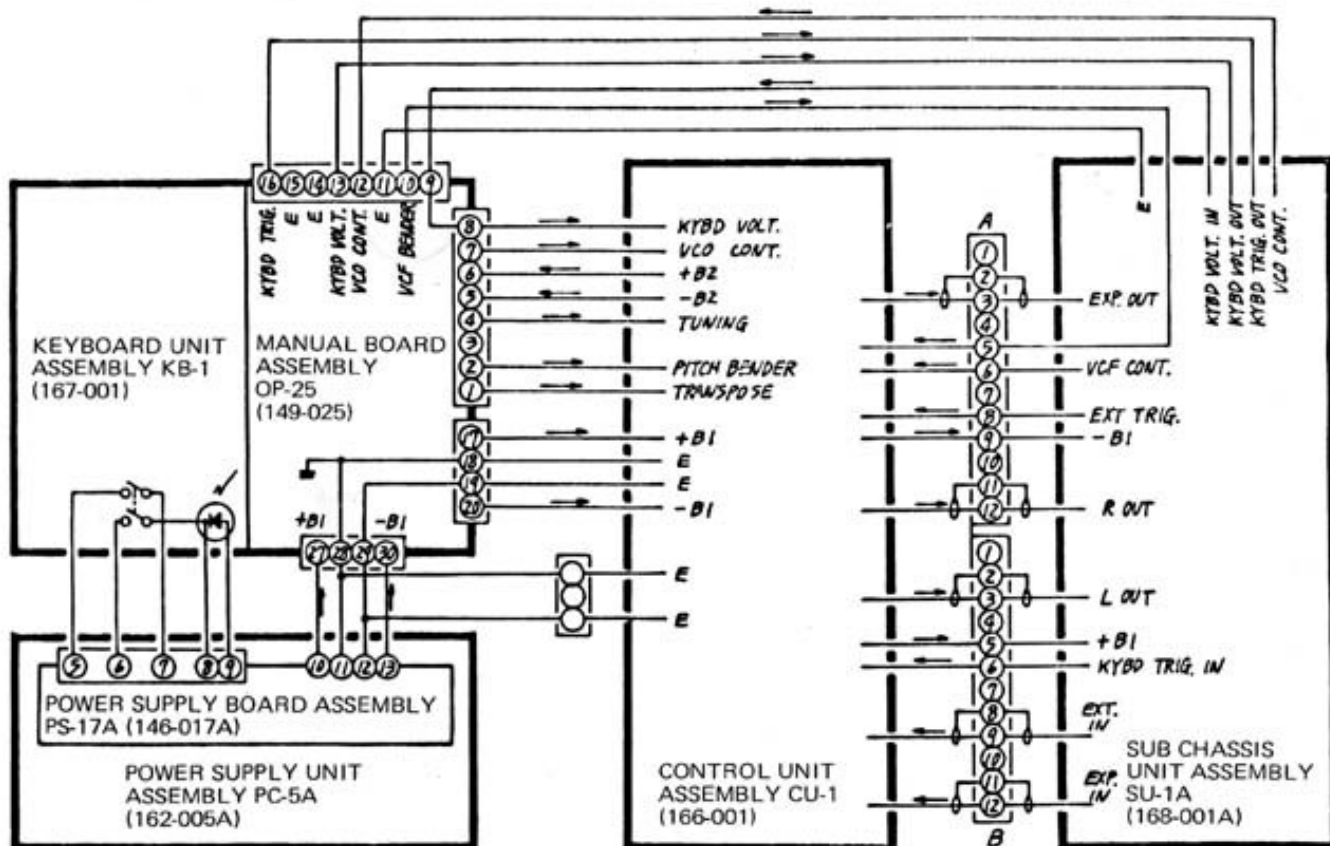
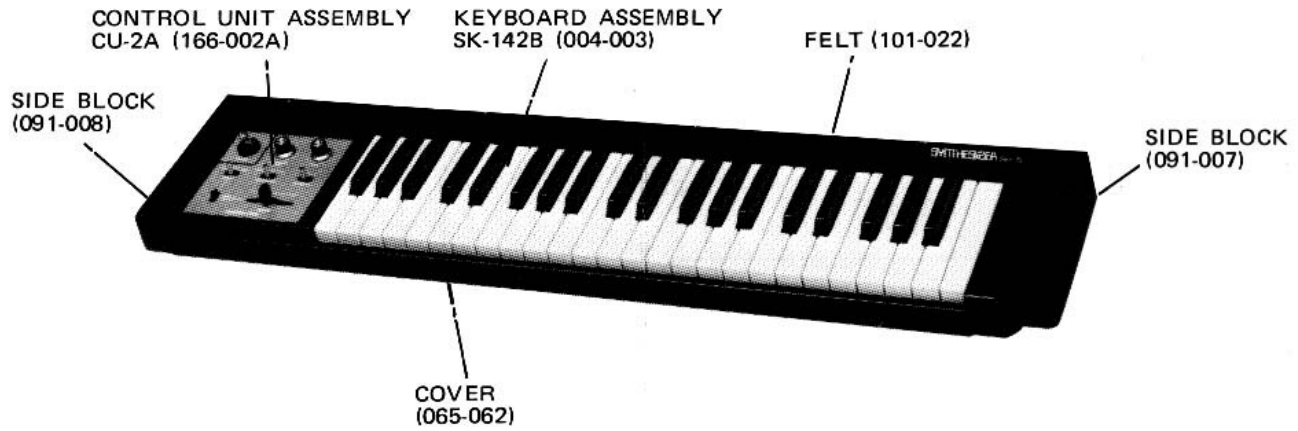

Fig. 5



7. WIRING BLOCK DIAGRAM





8-1. KEYBOARD ASSEMBLY SK-142B (004-003)

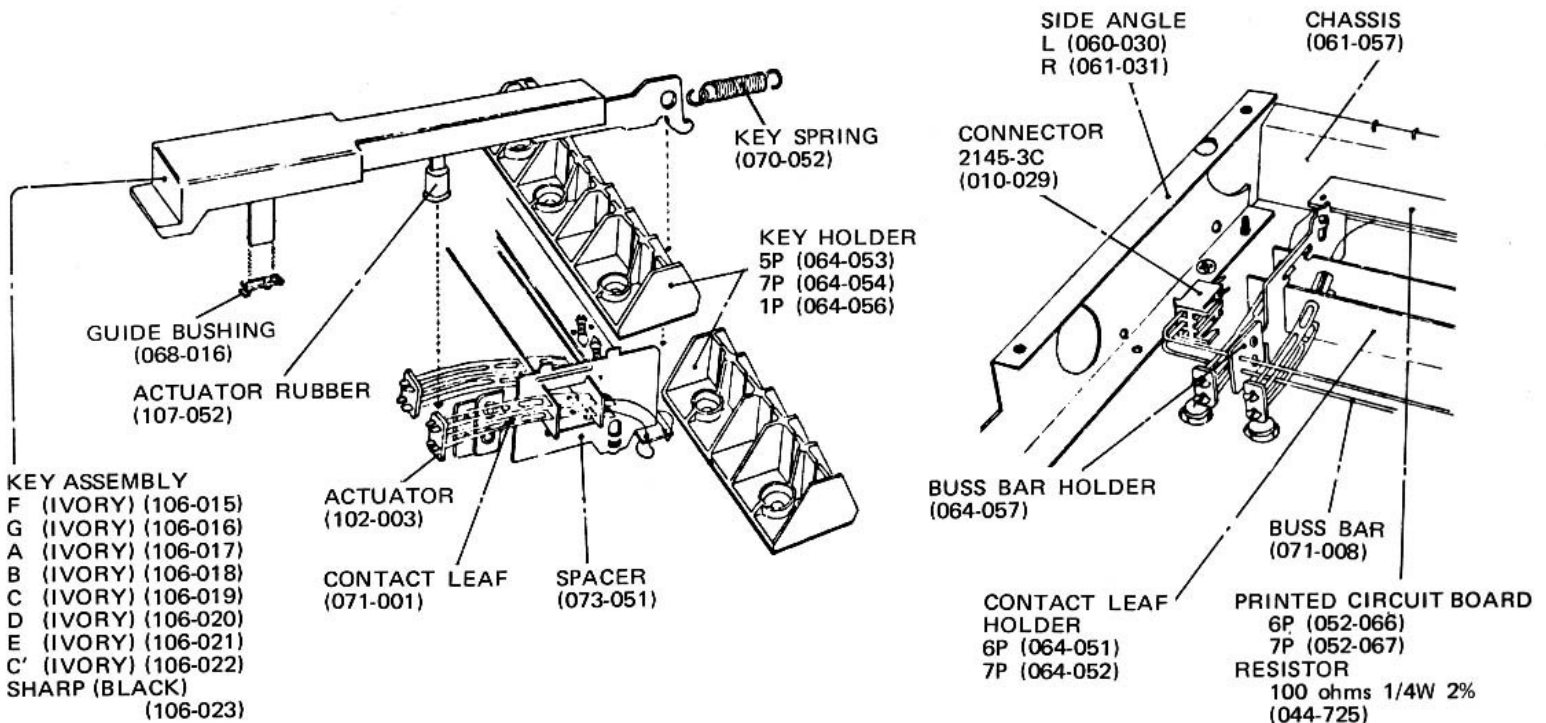

8-2. BENDER ASSEMBLY PB-1 (029-020)

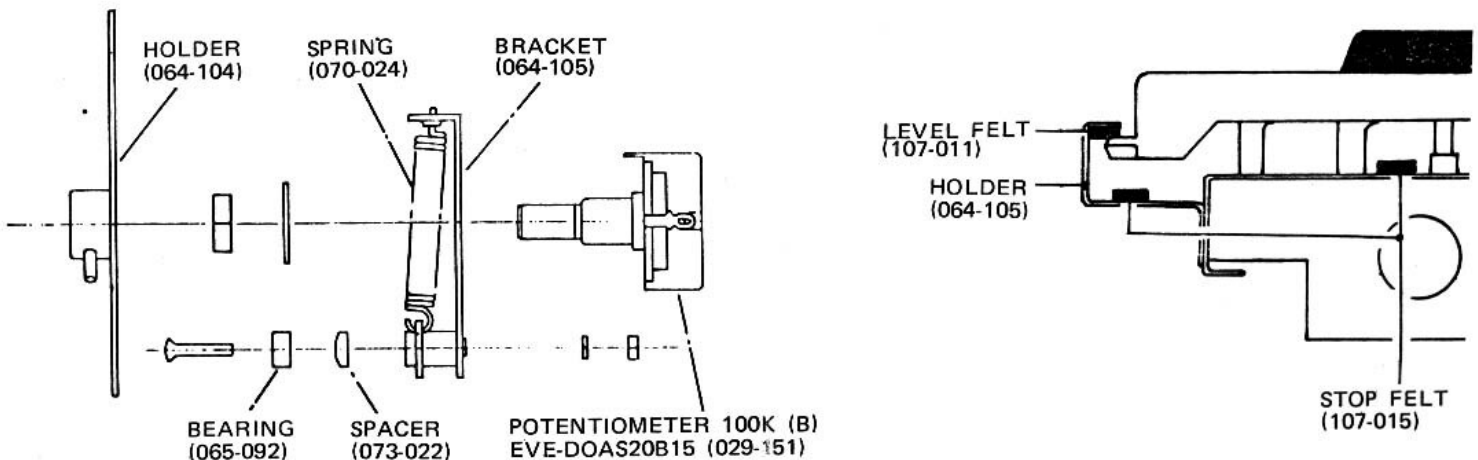

8-3. CONTROL UNIT ASSEMBLY CU-2A (166-002A)

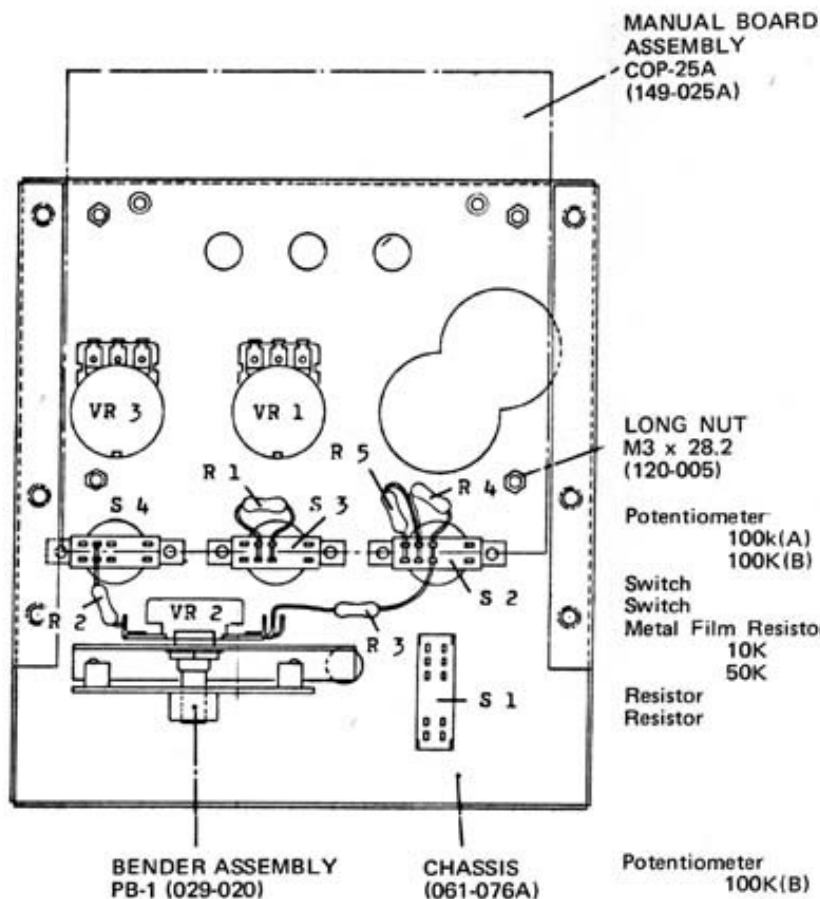
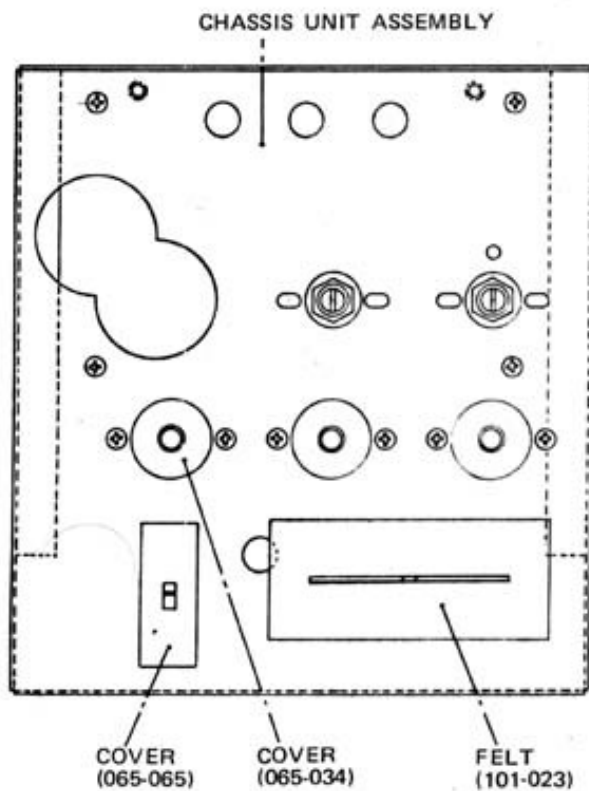
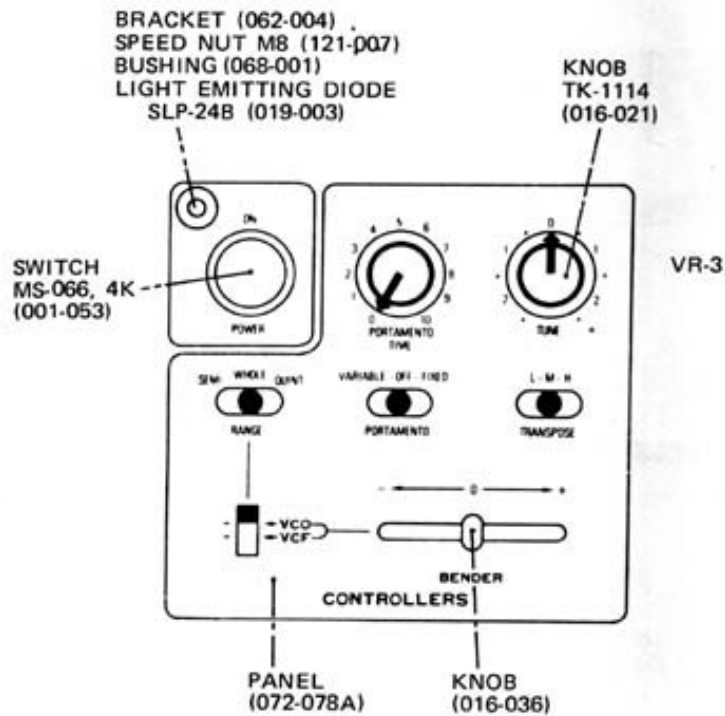

LONG NUT
 M3 x 28.2
 (120-005)

Potentiometer
 100k(A)
 100K(B)

Switch
 Switch
 Metal Film Resistors
 10K
 50K

Resistor
 Resistor







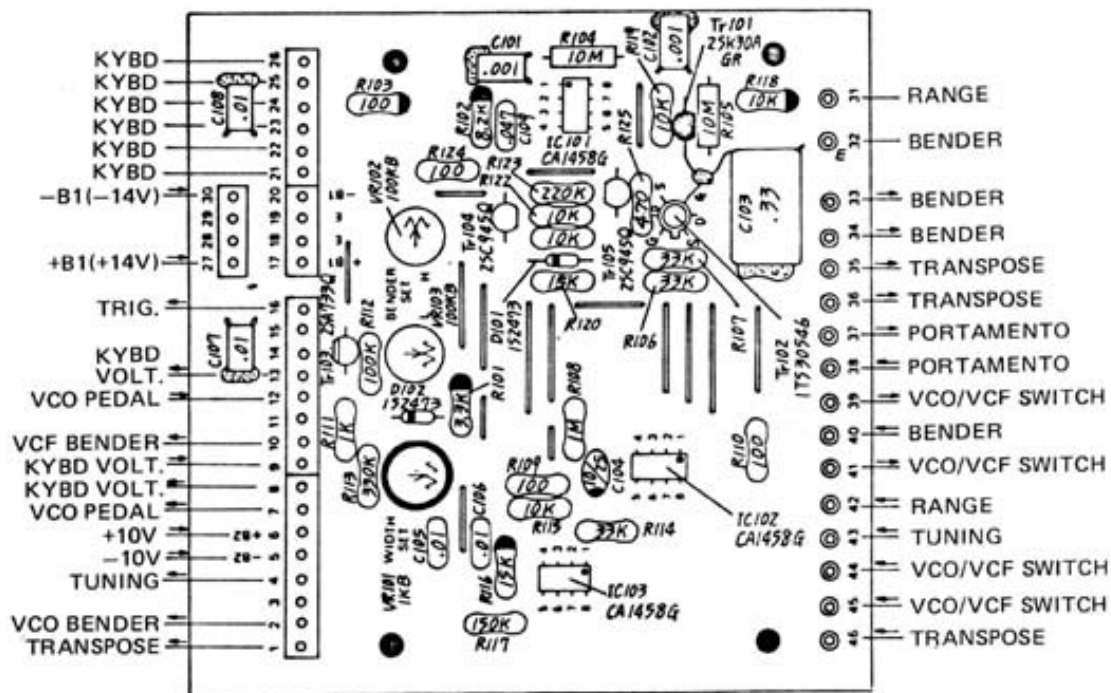

EVC-30AK15A15	VR1	029-190
EVE-DOAK15B15	VR3	029-030
SQ24-12C	S1	001-080
ESL-2412	S2, 3, 4	001-064
CRB-1/4FX 1%	R5	044-838
CRB-1/4FX 1%	R3, 4	044-861
4.7K 5%	R2	044-044
1 Meg 5%	R1	044-072

Potentiometer
 100K(B)

Serial No. Up to 450499
 EVC-BOAK15B15 VR3 028-334

8-4. MANUAL BOARD ASSEMBLY OP-25A (149-925A)



-  Metal Film Resistor CRB-1/4FX (1%)
-  Resistor 1/4R, J (5%)
-  Resistor ERC-12GK
-  Capacitor, Mylar (10%)
-  Capacitor, Ceramic (10%)
-  Capacitor, Tantalum (10%)
-  Transistor 2SC945Q
-  Transistor 2SA733Q
-  Diode 1S2473

8-5. KEYBOARD UNIT CIRCUIT KB-1 (SK-142B, CU-2A, OP-25A, PB-1)

1976-10-30 SH-5

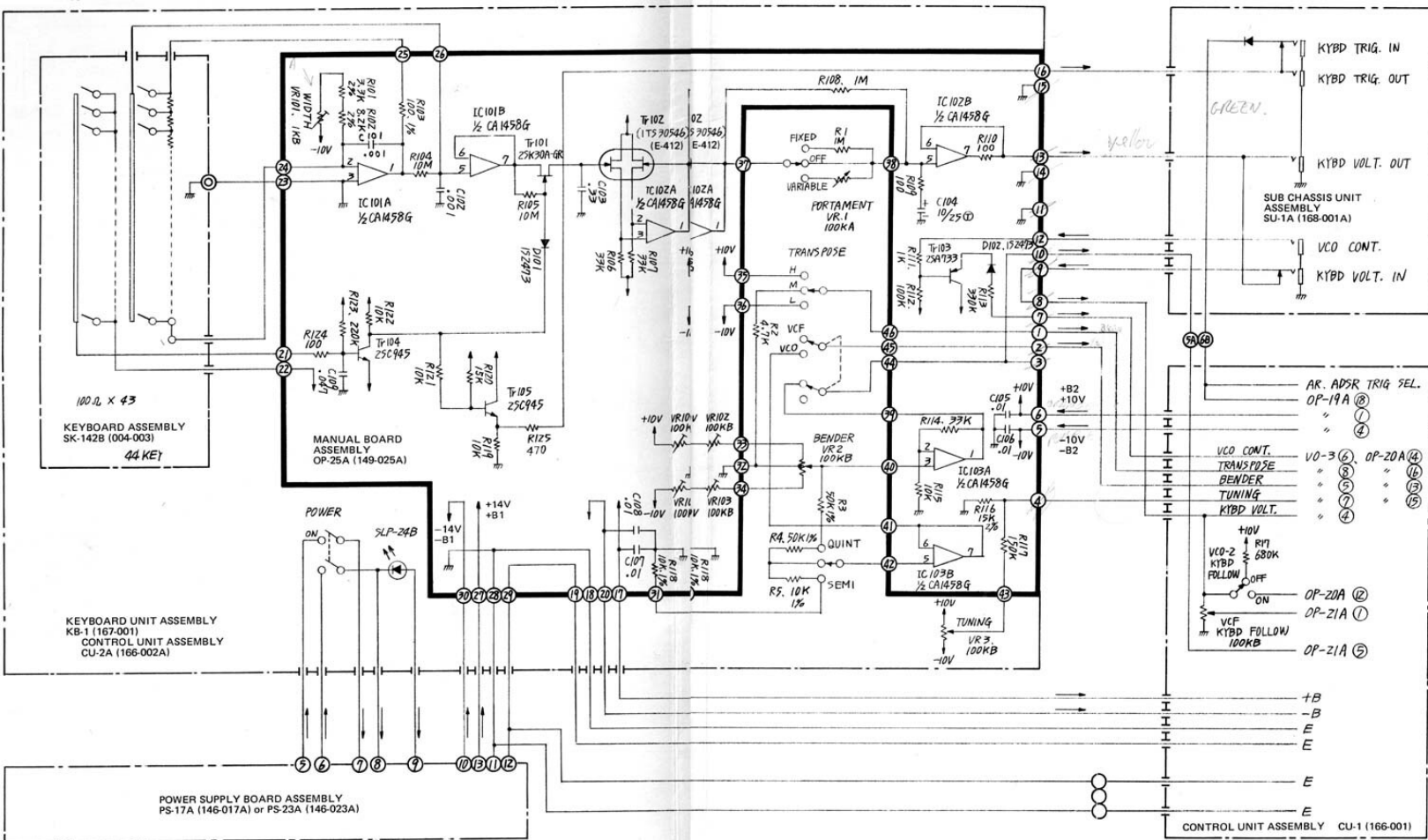

8-5. KEYBOARD UNIT CIRCUIT KB-1 (SK-142B, CU-2A, OP-25A, PB-1)

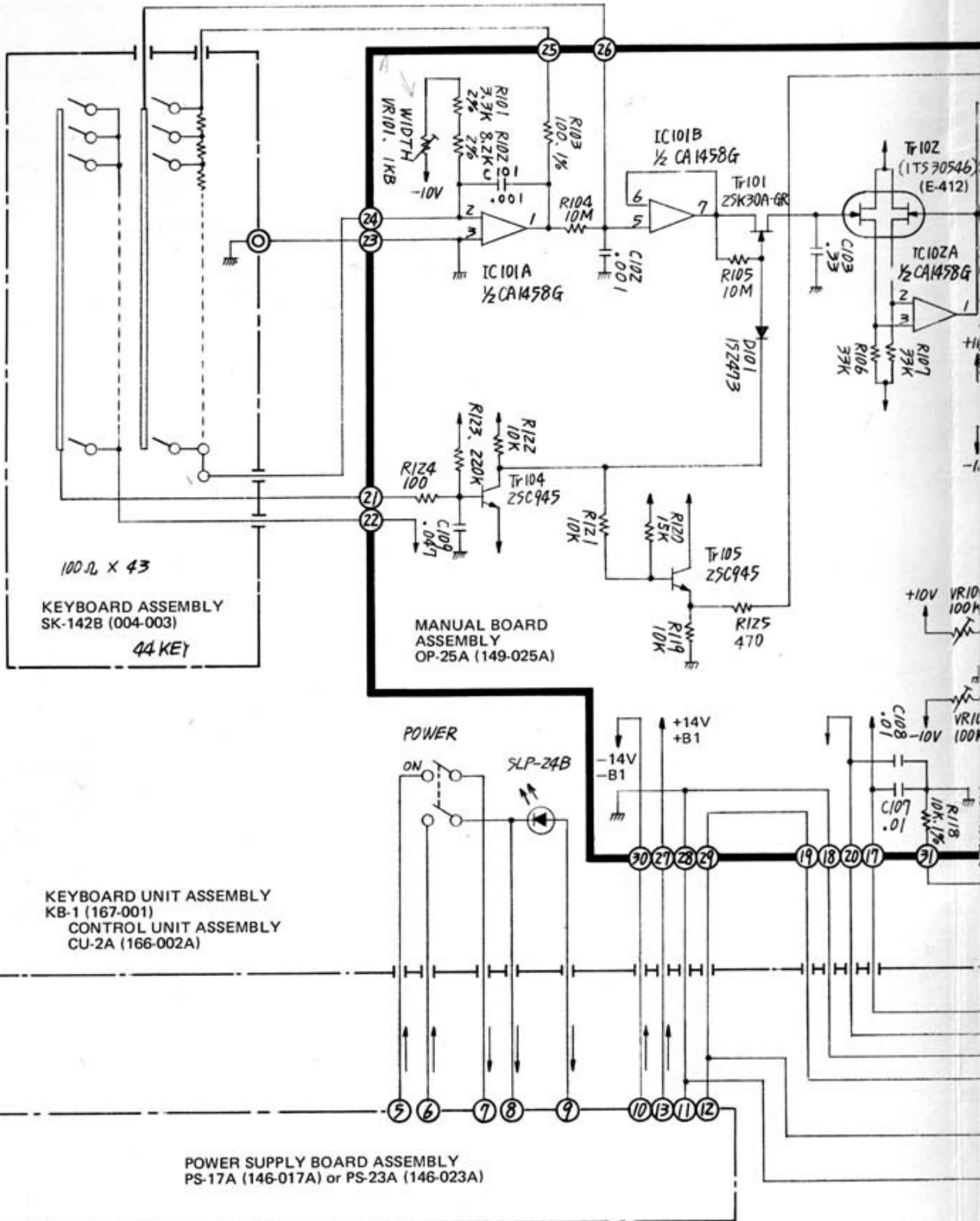

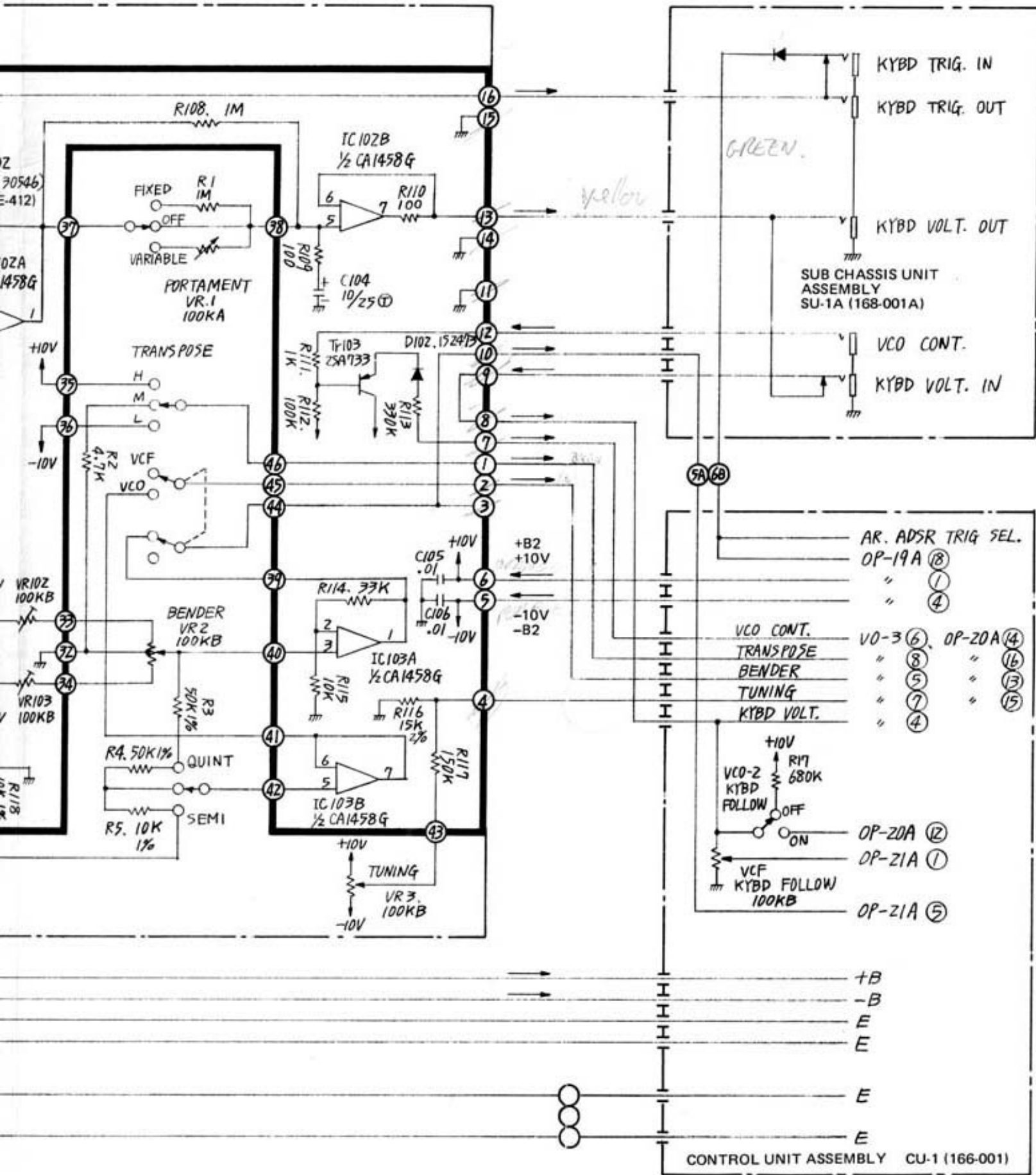
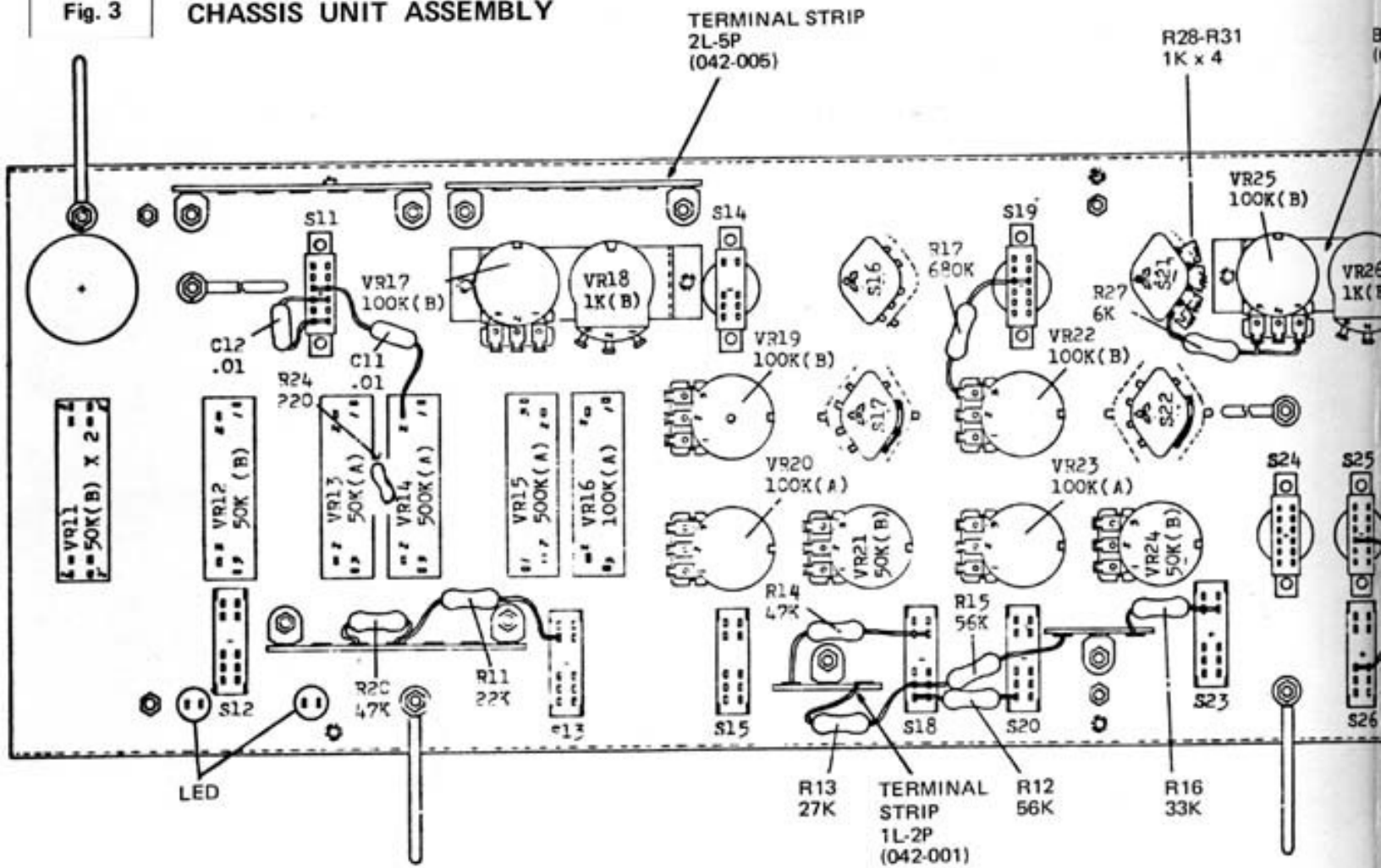

Fig. 3

CHASSIS UNIT ASSEMBLY



Potentiometer

50K(A)	EVA-QOAC16A54	VR13	028-035
50K(B)	EVA-QOAC16B54	VR12, 31	028-024
100K(A)	EVA-QOAC16A15	VR16	028-036
100K(B)	EVA-QOAC16B15	VR41	028-025
500K(A)	EVA-QOAC16A55	VR14, 15	028-038
1 Meg (A)	EVA-QOAC16A16	VR43	028-039
2 Meg (D)	EVA-QOAC16D26	VR39, 40, 42, 44	028-098
50K(B)	EVB-FOAC16B54	VR11	029-157
100K(A)	EVB-FOAC16A15	VR32	029-168
1K(B)	EVR-20AS15B13	VR18, 26	029-002
50K(B)	EVC-BOAK20B54	VR21, 24, 30, 33, 36	029-175
100K(A)	EVC-BOAK20A15	VR20, 23	029-186
100K(B)	EVC-BOAK20B15	VR28, 29, 34, 37	029-176
100K(B)	EVC-BOAS15B15	VR17, 25	029-116
100K(B)	EVE-D3AK20B15	VR19	029-032
100K(B)	EVE-DOAK20B15	VR22	029-031
10K(B)	EWf-POAK20B14	VR35	029-082
10K(A, C)		VR38	029-150
100K(C)	EWf-POAK20C15	VR27	029-134

Serial No. Up to 450499

100K(B)	EVC-BOAK20B15	VR19	029-149
100K(B)	EVC-BOAK20B15	VR22	029-176

1976-10-30 SH-5

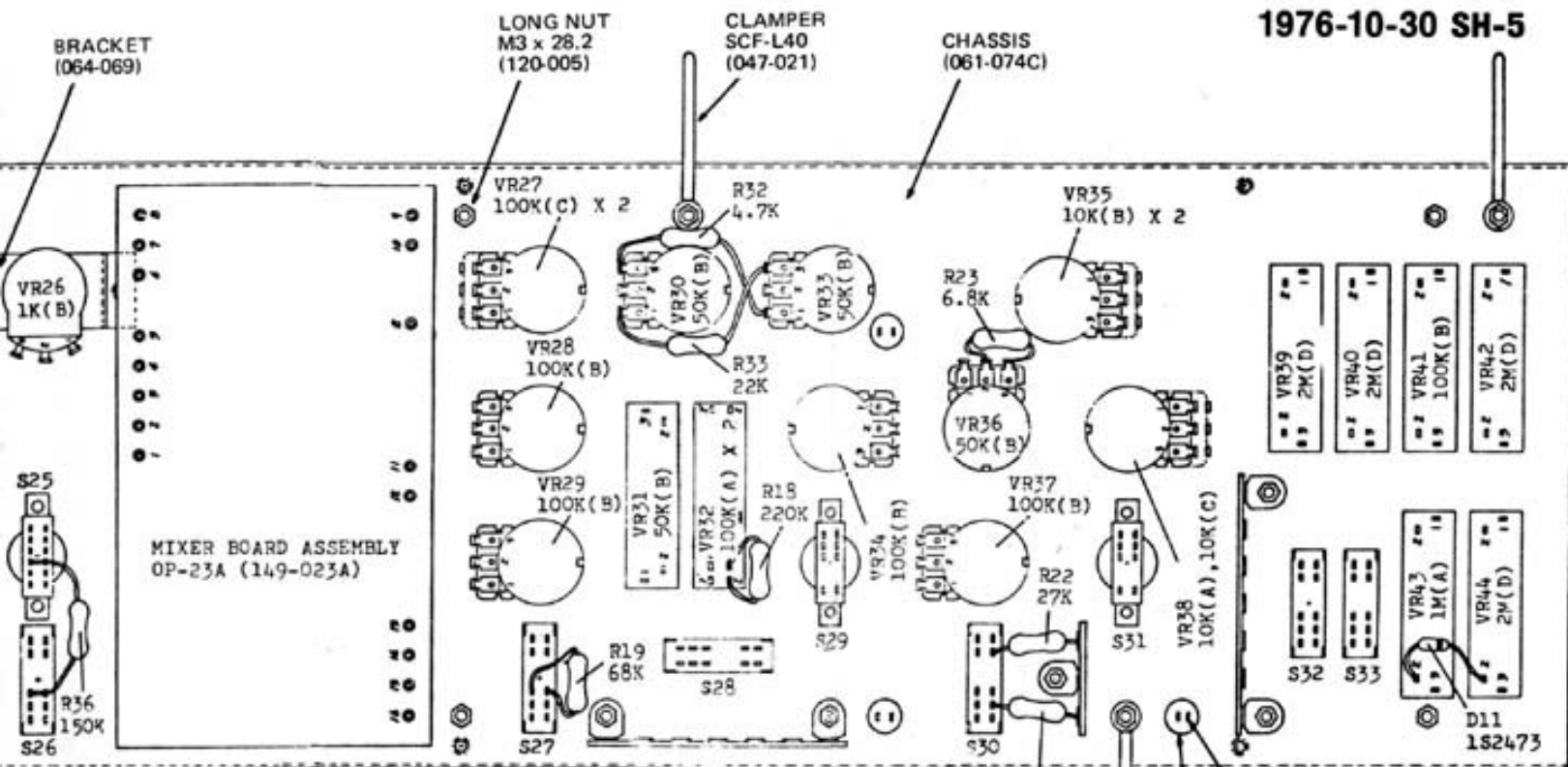

Switch	ESR-E124K20	S17, 22	001-078
Switch	ESR-E115K20	S16, 21	001-079
Switch	ESL-2411	S11, 19, 24, 25	001-065
Switch	ESL-2412	S14, 29, 31	
Switch	SQ142-12C	S12, 13, 15, 18, 20, 23, 26, 27, 28, 30, 32, 33	001-080

Metal Film Resistor			
1K	CRB-1/4FX 1%	R28, 29, 30, 31	044-830
Diode	1S2473	D11	018-014
Capacitor, Mylar	.01 mf	C11, 12	035-016
Connector Housing	2145-4A		010-022
Connector Housing	2145-6A		010-023
Connector Housing	2145-8A		010-024
Connector Housing	1625-3P		010-045
Connector Housing	1625-12P		010-011
Pin Terminal	1560T		042-013
VR Washer	M8		121-001
Resistor 1/4W 5% are omitted.			

LIGHT EMITTING DIODE
LD-64R (019-004)
or LR0601R (019-009)
BUSHING
(068-020)

9-1. CONTROL UNIT CIRCUIT (CU-1) (OP-19B, VO-3A, OP-20B, OP-23A, OP-21B, OP-22A.)

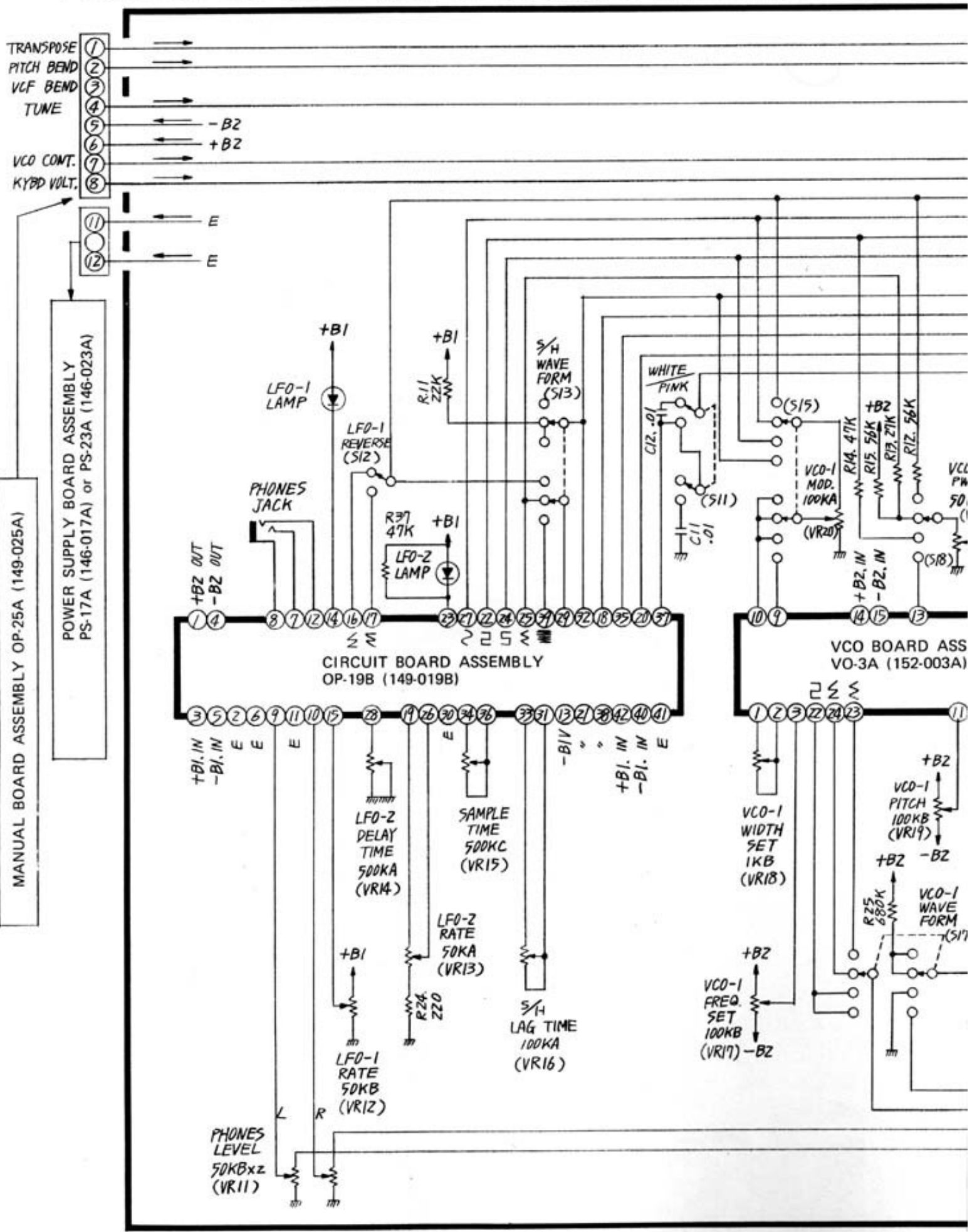

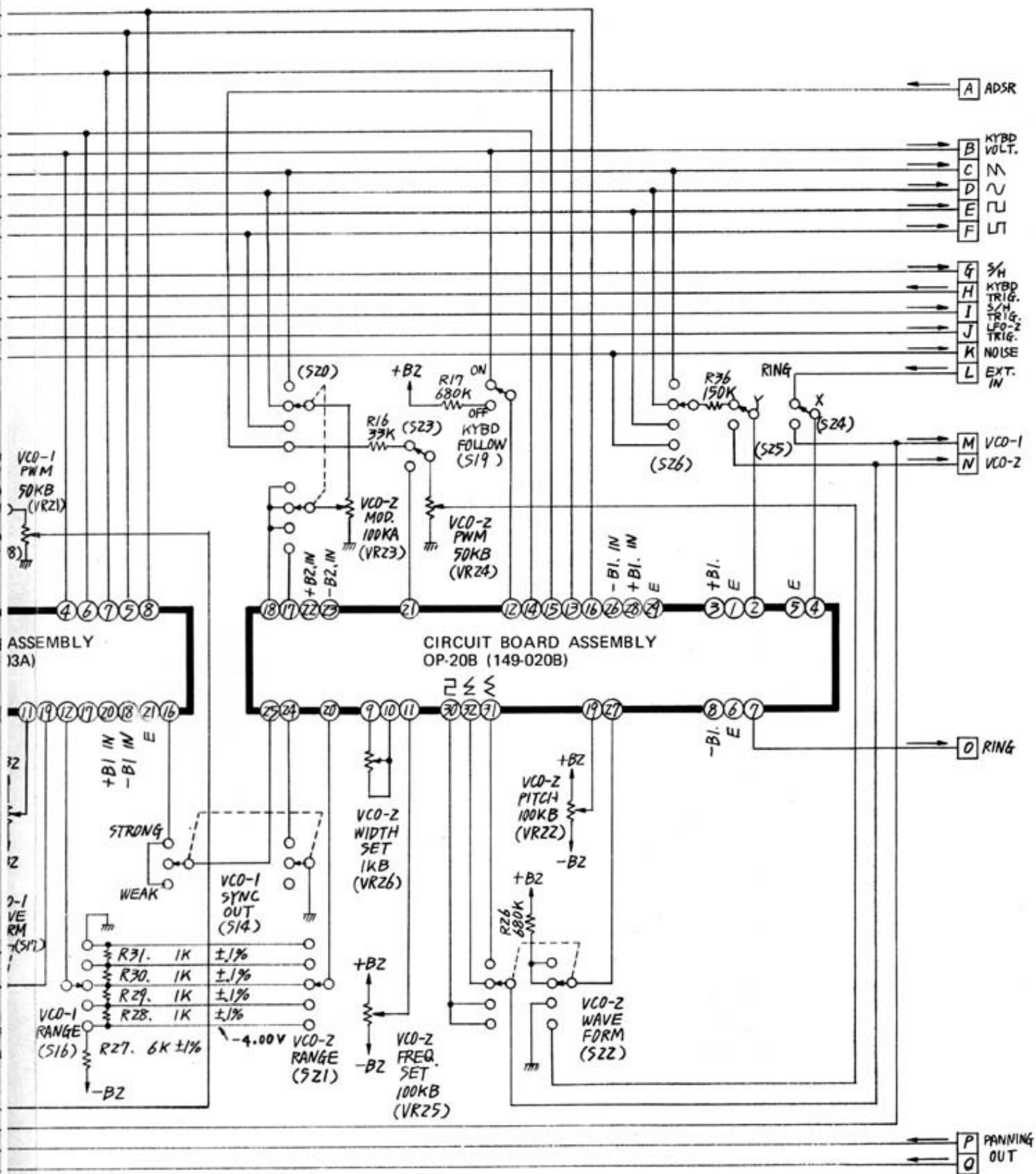
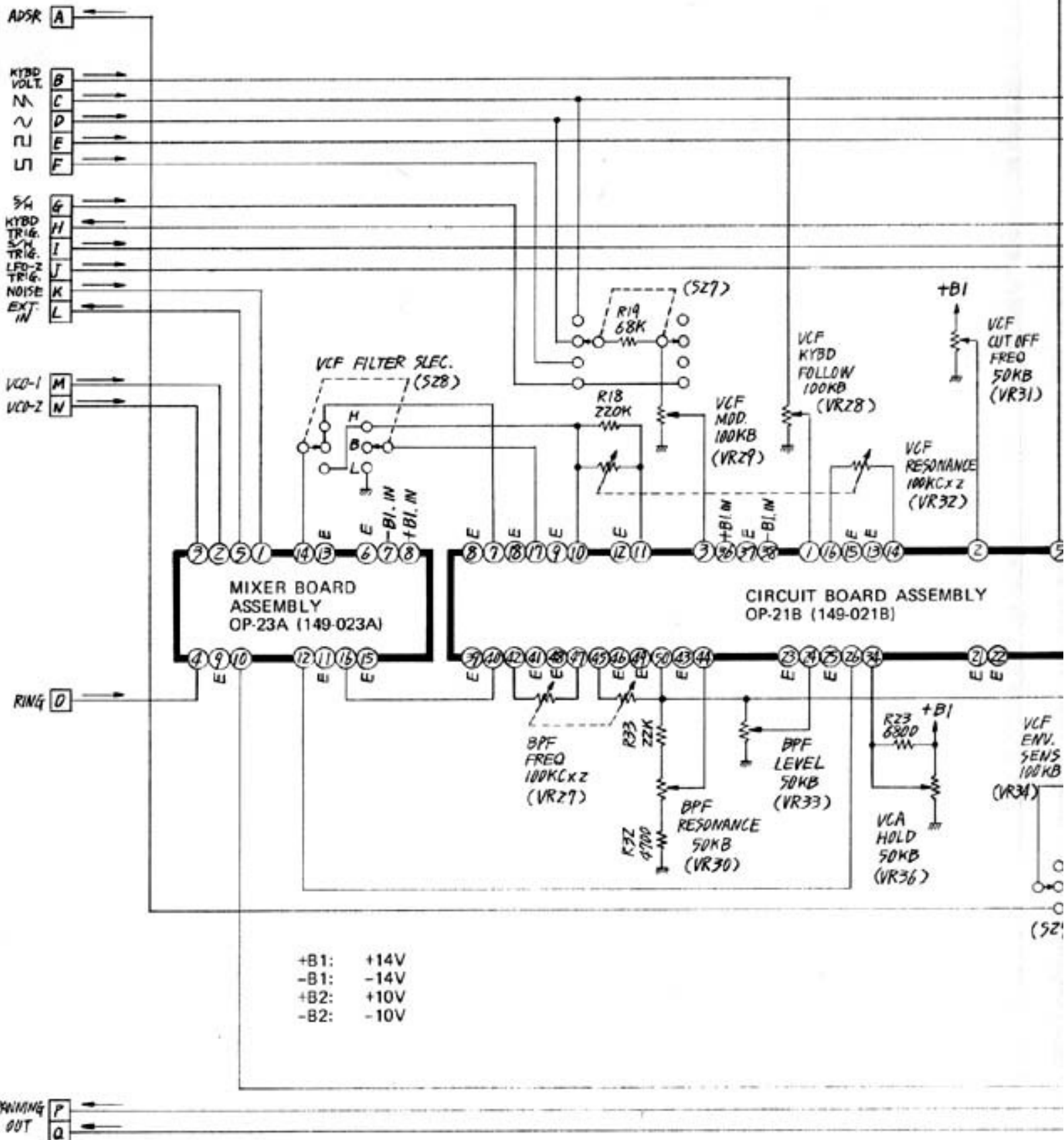
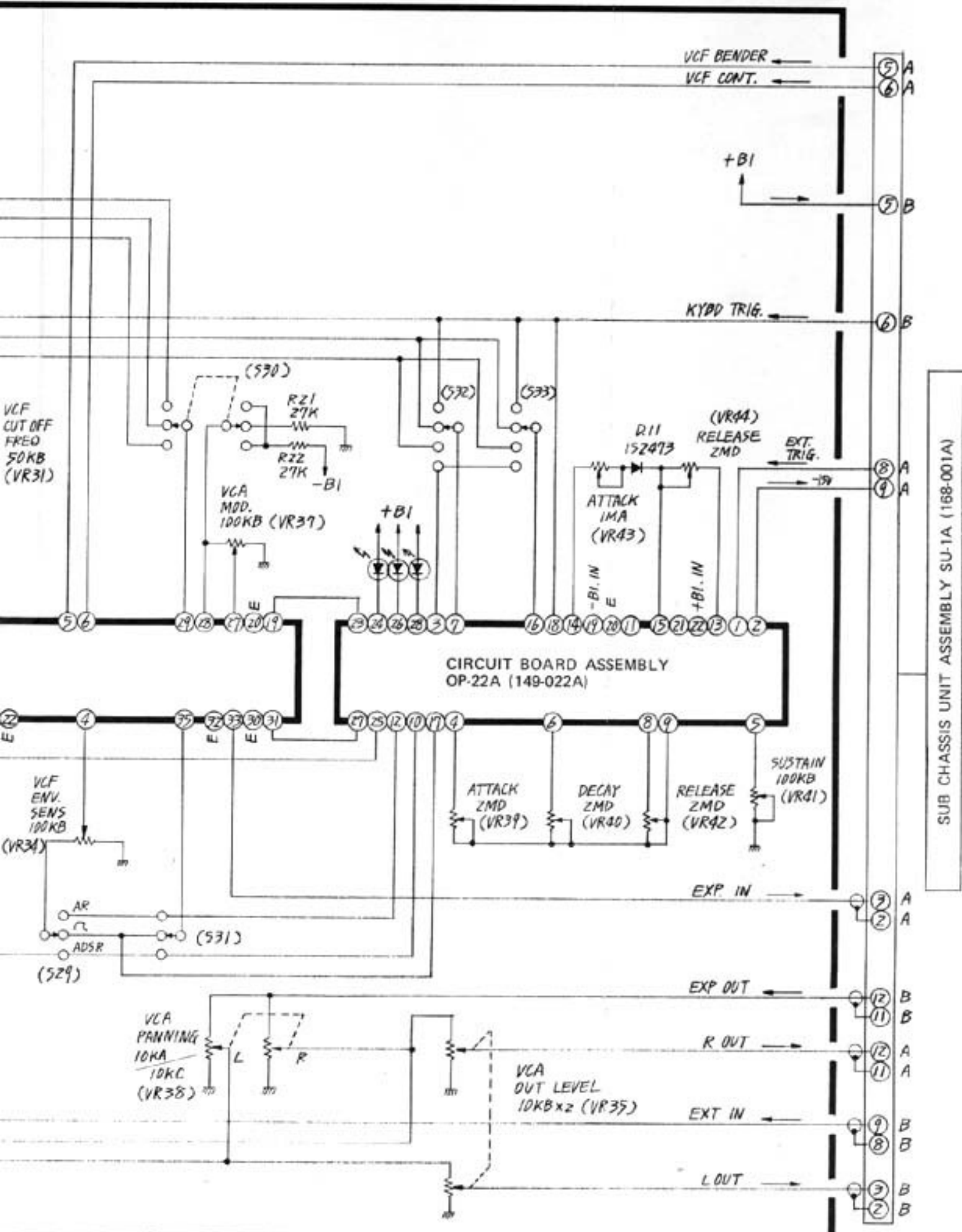

Fig. 2

CONTROL UNIT ASSEMBLY CU-1 (166-001)





1976-10-30 SH-5

9-2. CIRCUIT BOARD ASSEMBLY OP-19A (149-019A)

Serial No. Up to 440399

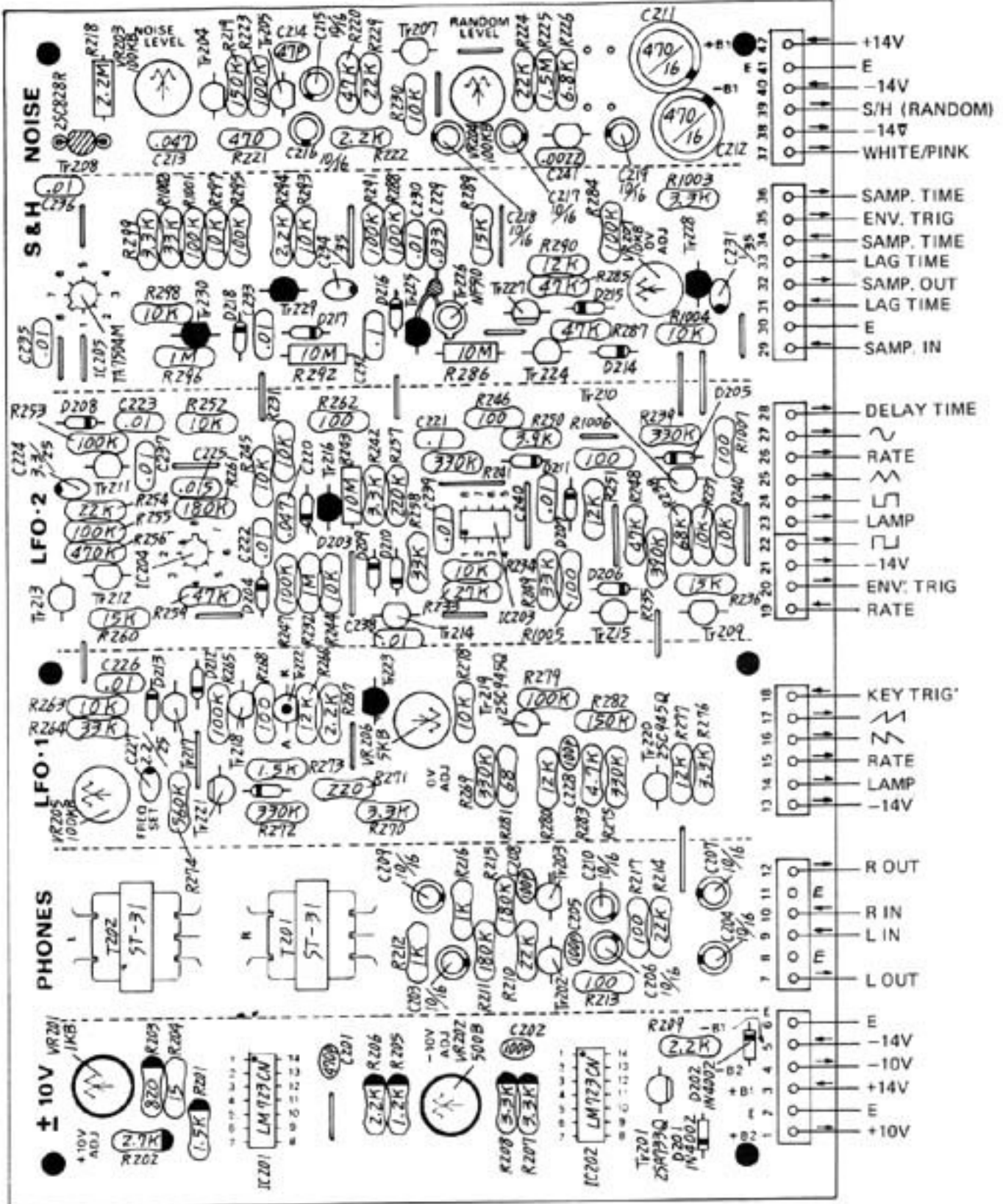

9-2a. CIRCUIT BOARD ASSEMBLY OP-19B (149-019B)

Serial No. 450400 and Higher

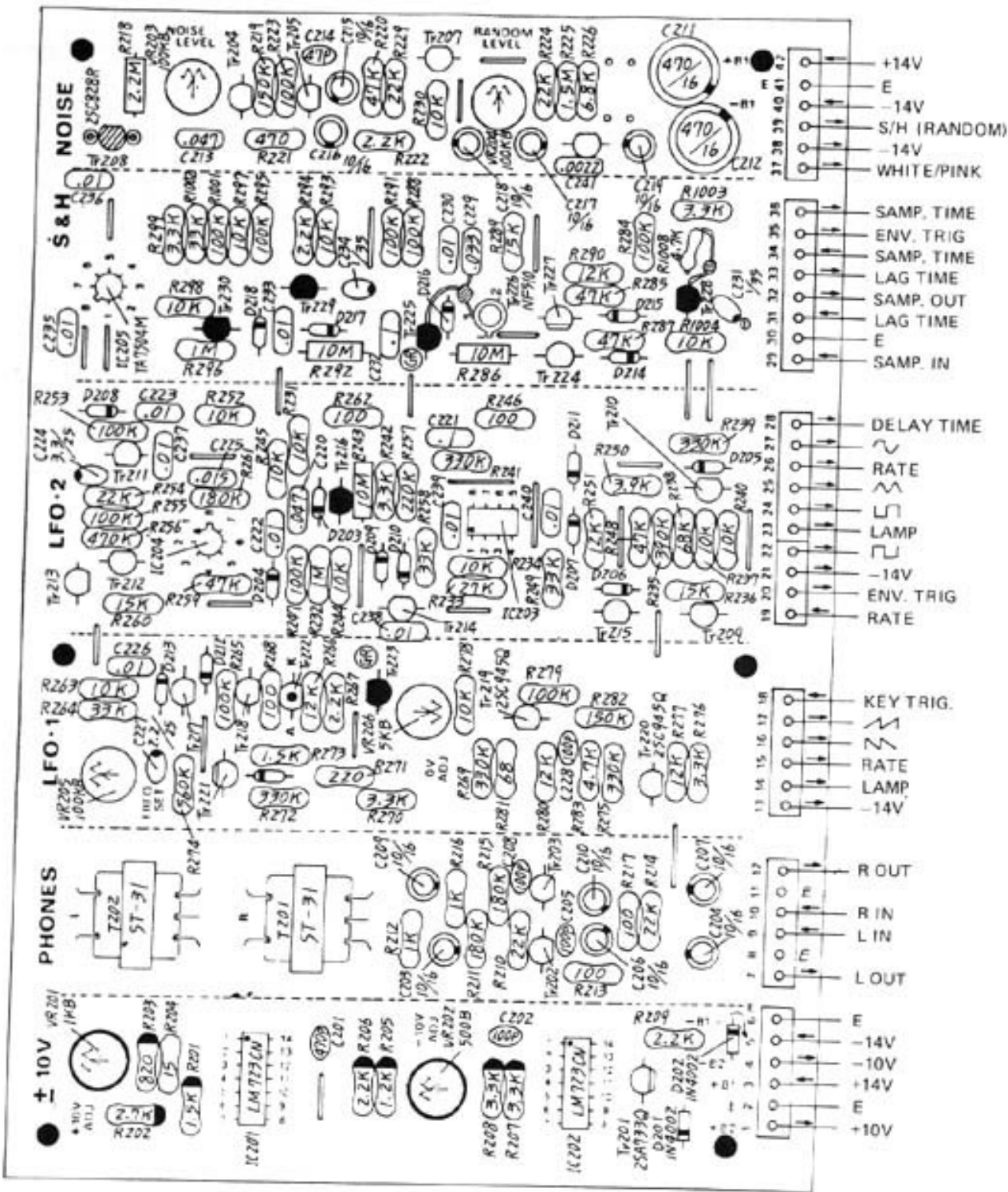

- | | | | |
|--|------------------------------------|--|---|
| | Metal Film Resistor CRB-1/4FX (1%) | | Transistor 2SC945Q |
| | Resistor 1/4R, J (5%) | | Transistor 2SA733Q |
| | Resistor ERC-12GK | | Field Effect Transistor 2SK30A-GR |
| | Capacitor, Mylar (10%) | | Programmable Unijunction Transistor N13T1 |
| | Capacitor, Ceramic (10%) | | Diode 1S2473 |
| | Capacitor, Tantalum (10%) | | |
| | Capacitor, Electrolytic | | |

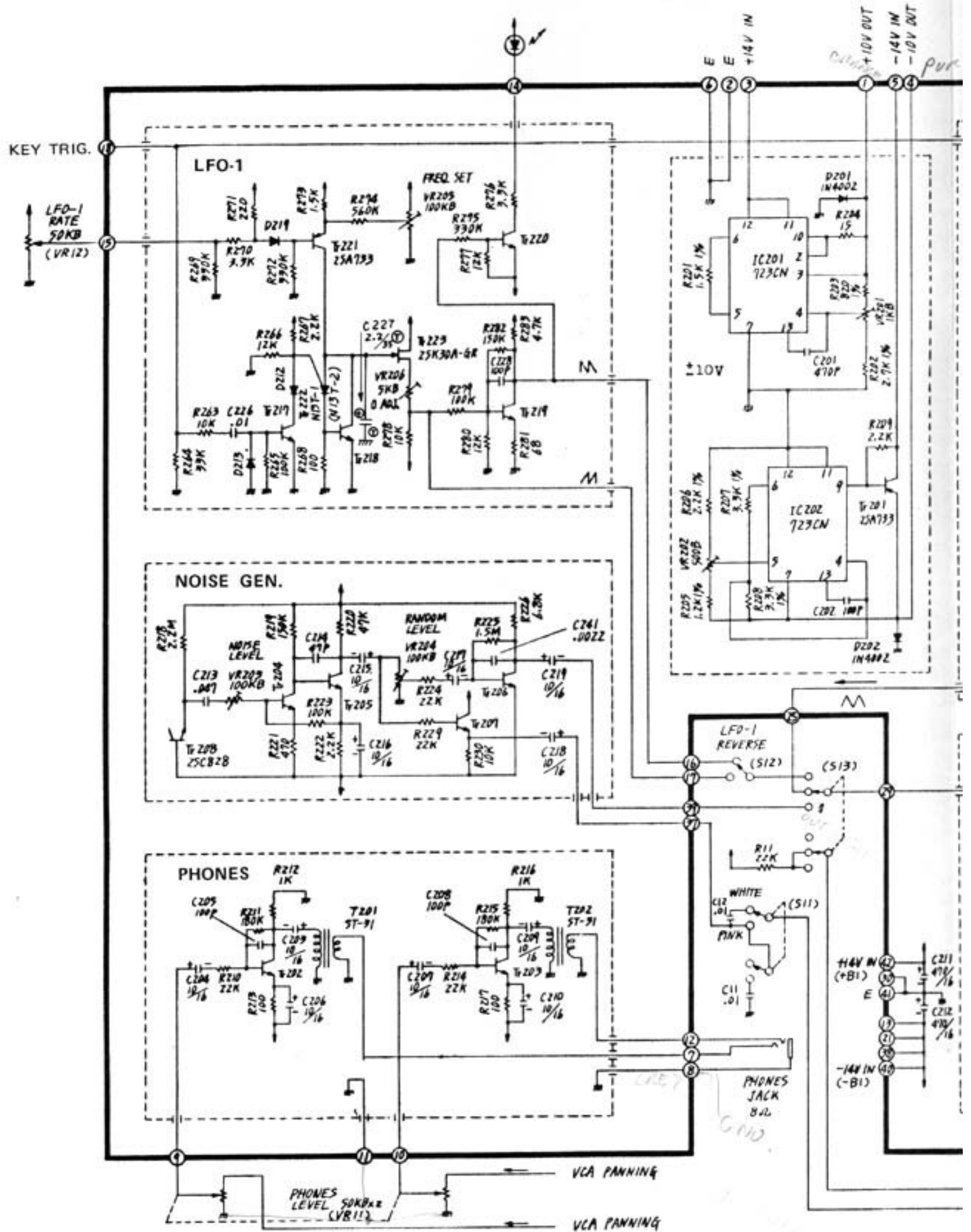

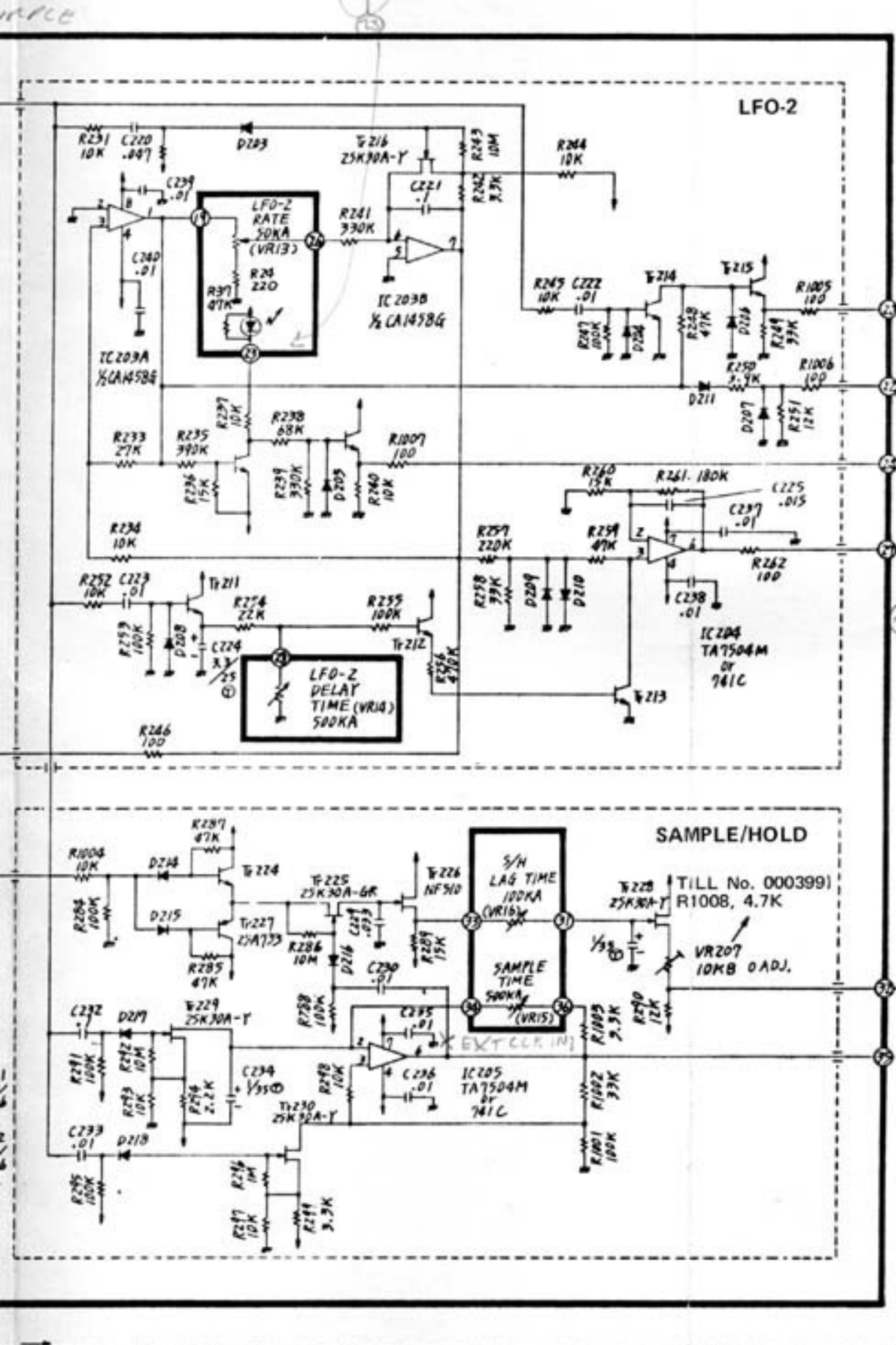





LFO-2

- ① LFO TRIG. OUT. (AR, ADSR)
- ② VCO-1 PULSE WIDTH RING MOD. VCA MOD.
- ③ VCO-1 MOD. VCF MOD. VCO-2 MOD.
- ④ VCO-1 MOD. VCF MOD. VCO-2 MOD. VCA MOD.

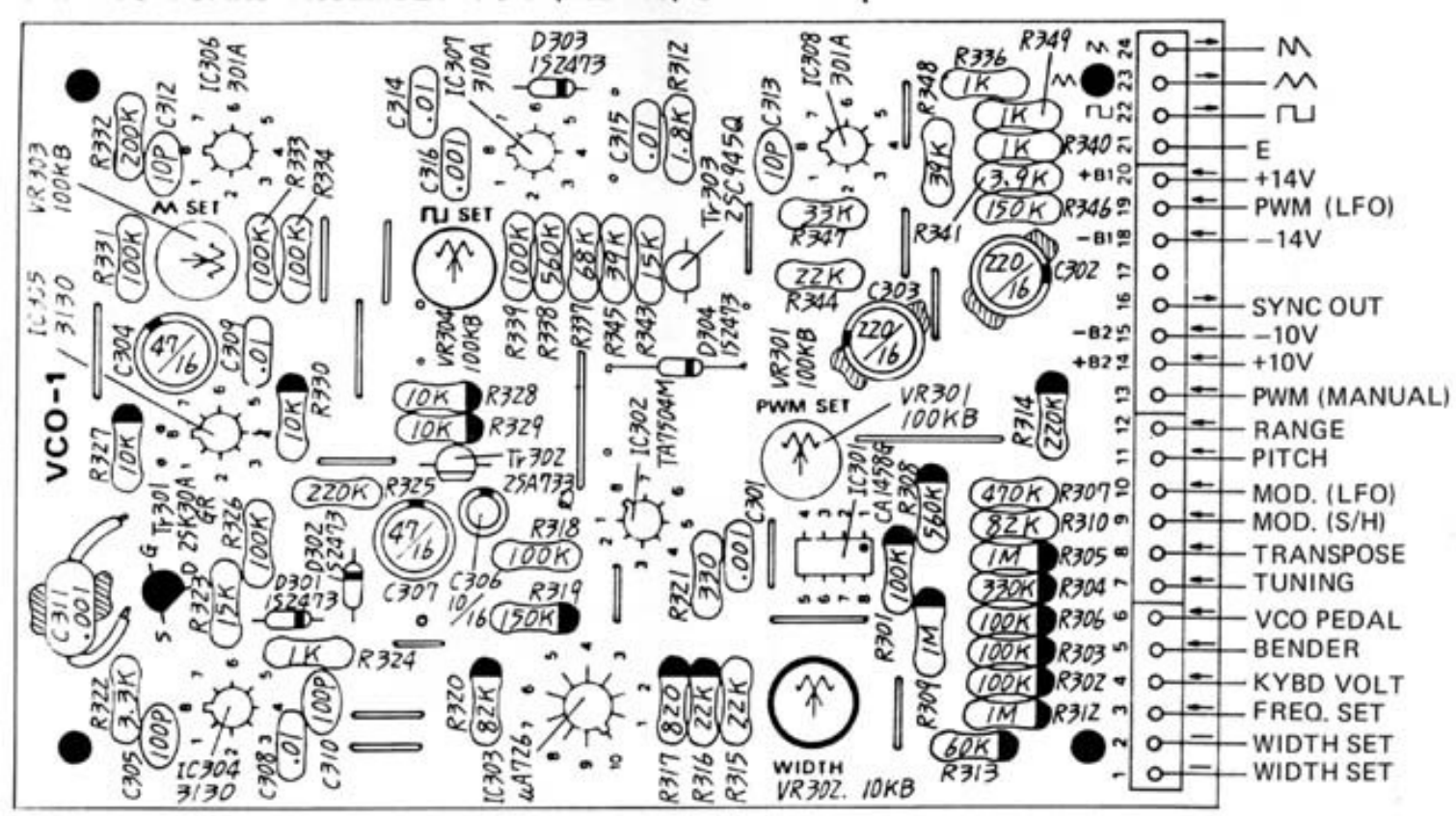
SAMPLE/HOLD

- ⑤ S/H (VCO-1 MOD. OUT(VCF MOD.))
- ⑥ (ENV-GEN.) TRIG SW
- ⑦ LOCK OUT



-  Metal Film Resistor CRB-1/4FX (1%)
-  Resistor 1/4R, J (5%)
-  Resistor ERC-12GK
-  Capacitor, Mylar (10%)

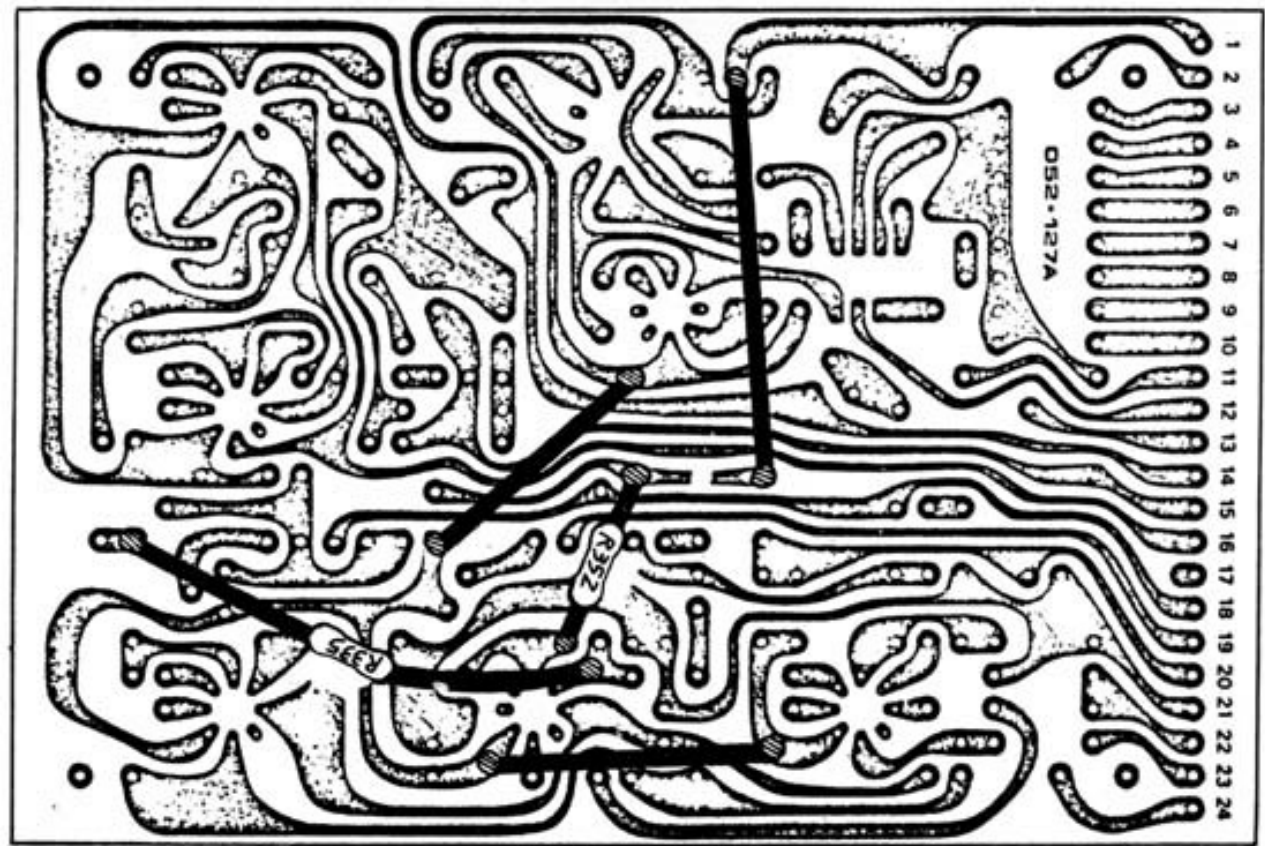

9-4a. VCO BOARD ASSEMBLY VO-3A (152-003A) Serial No. 450400 to 490949

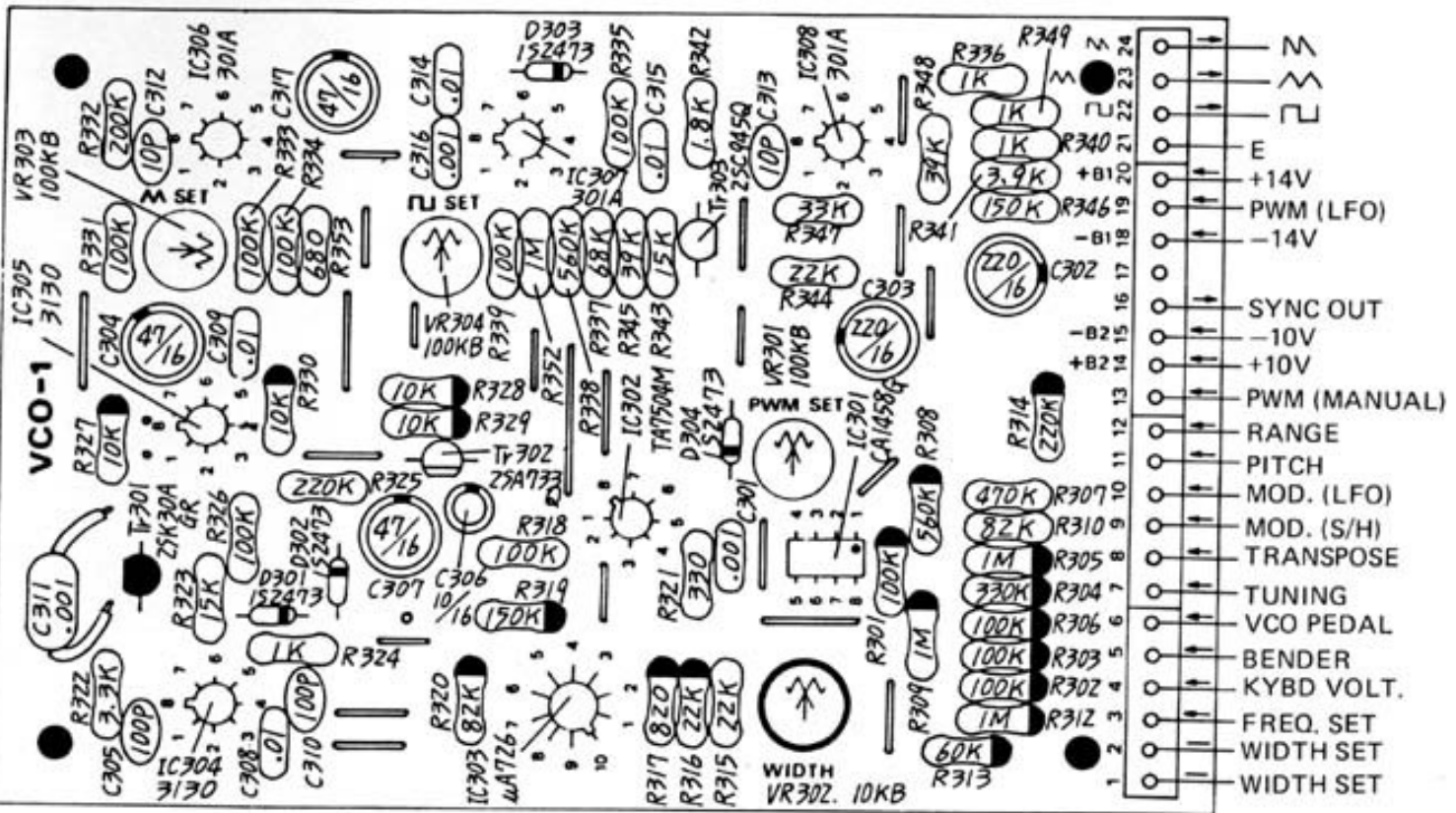

- Capacitor, Ceramic (10%)
- Capacitor, Tantalum (10%)
- Capacitor, Electrolytic
- Transistor 2SC945Q
- Transistor 2SA733Q
- Field Effect Transistor 2SK30A-GR
- Diode 1S2473

9-4-2. VCO BOARD ASSEMBLY VO-3B (152-003B) Serial No. 500950 and Higher

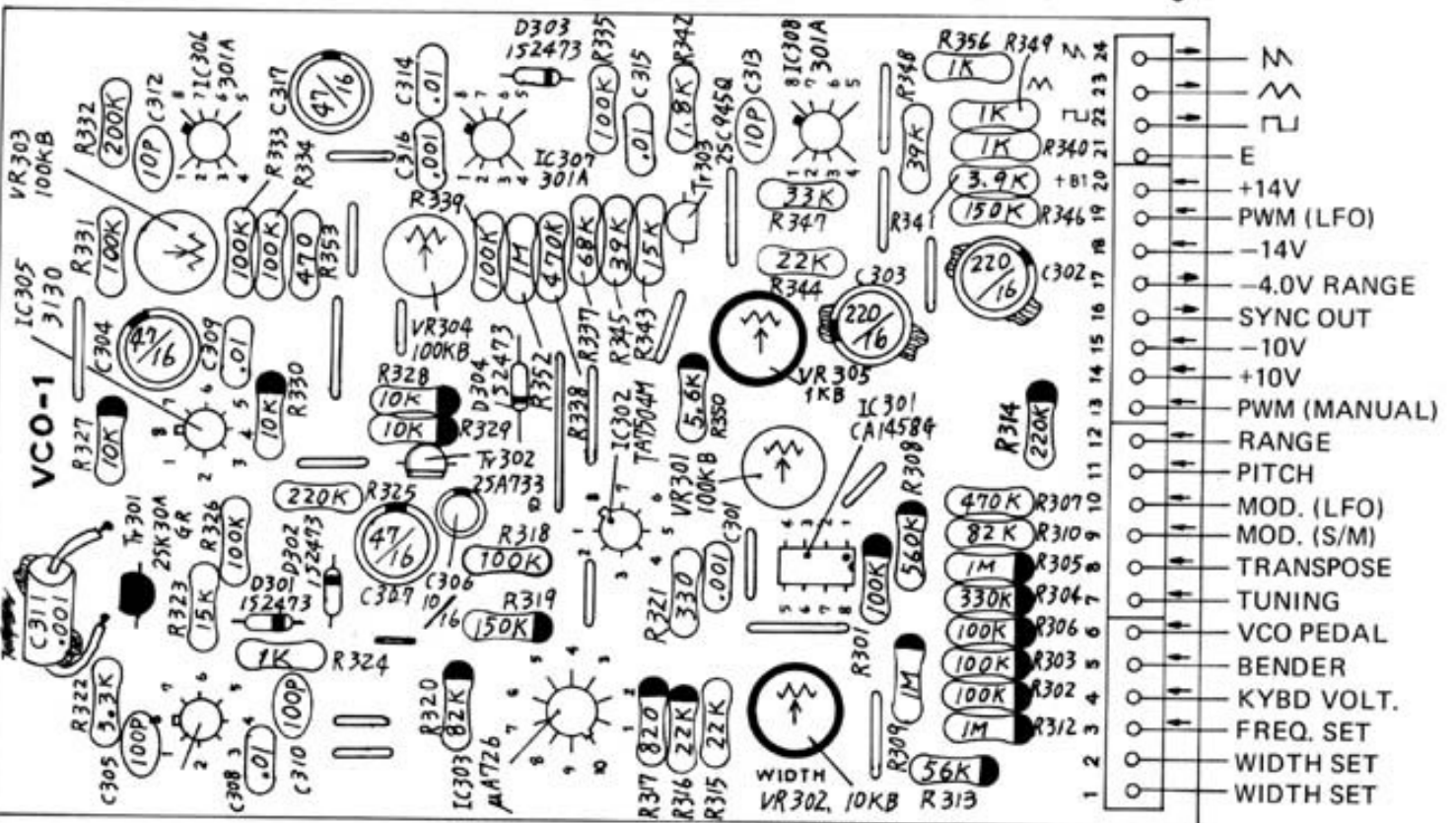

9-5. CIRCUIT DIAGRAM (VO-3B) (VCO-1) Serial No. 500950 and Higher

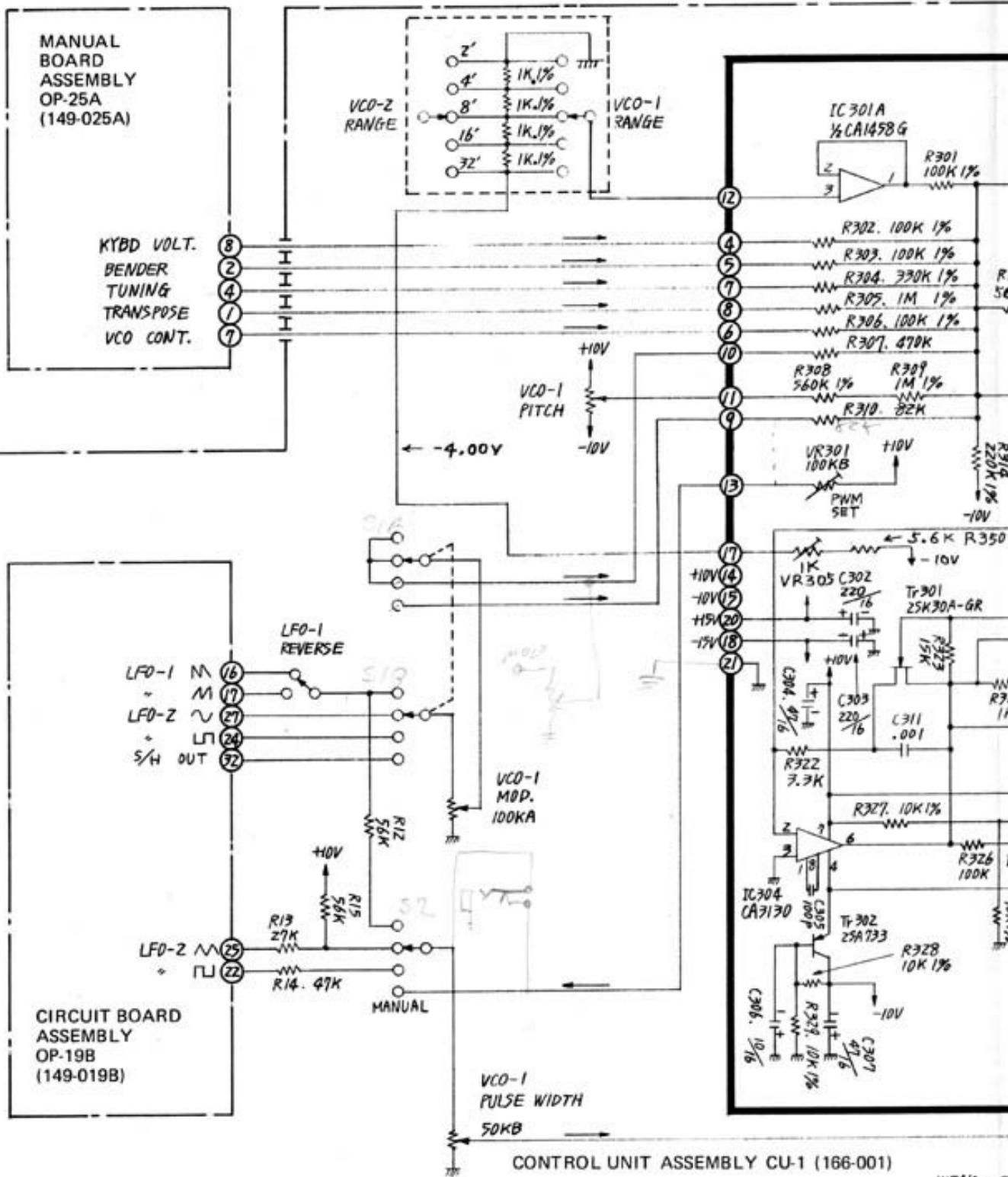
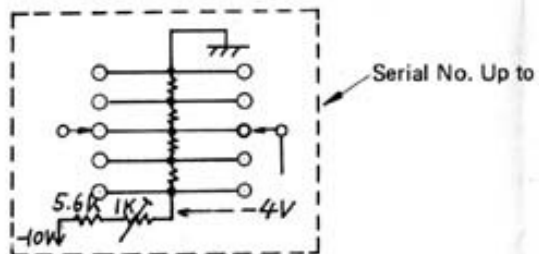

- WEAK ○
- OFF ○
- STRONG ○



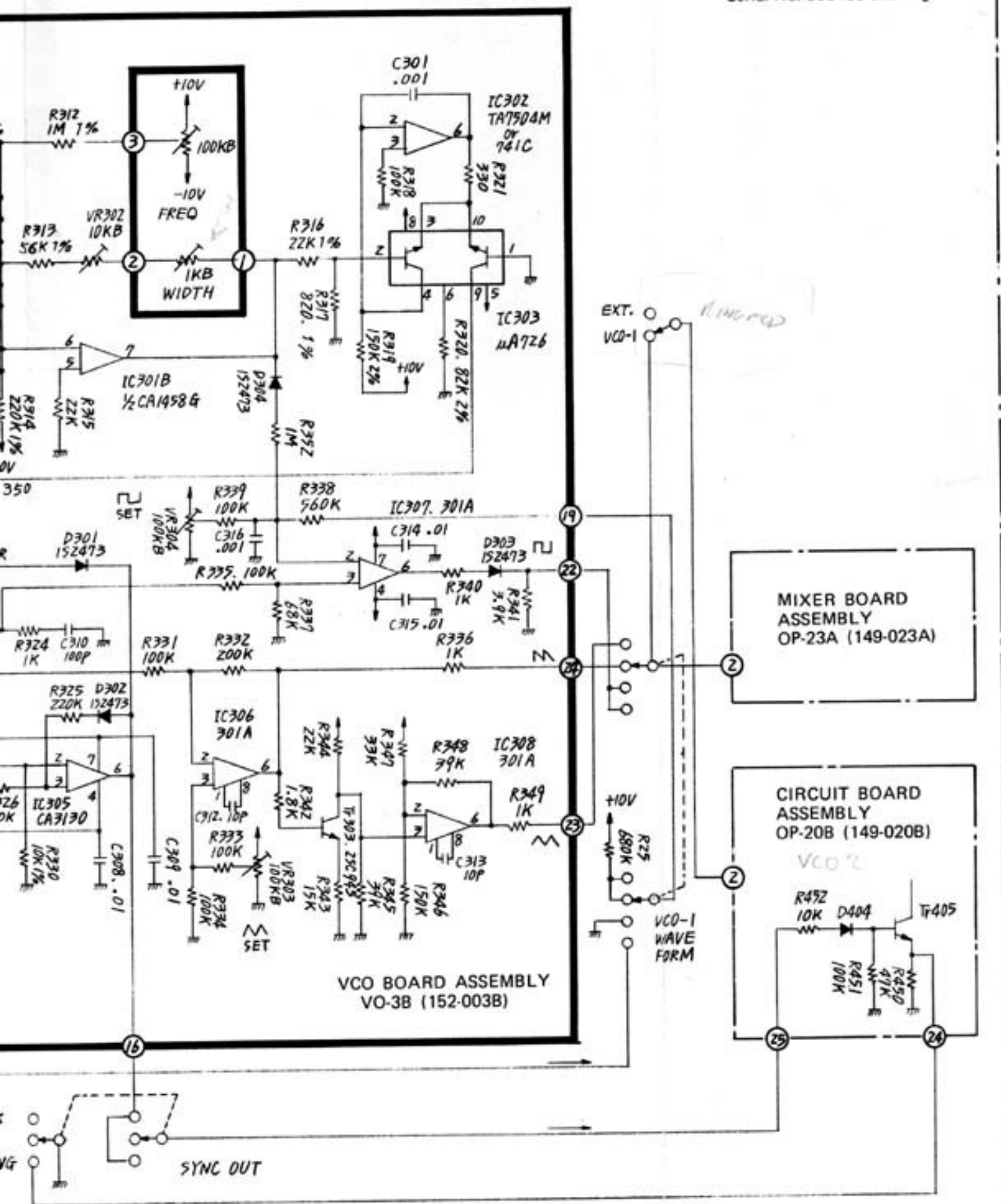



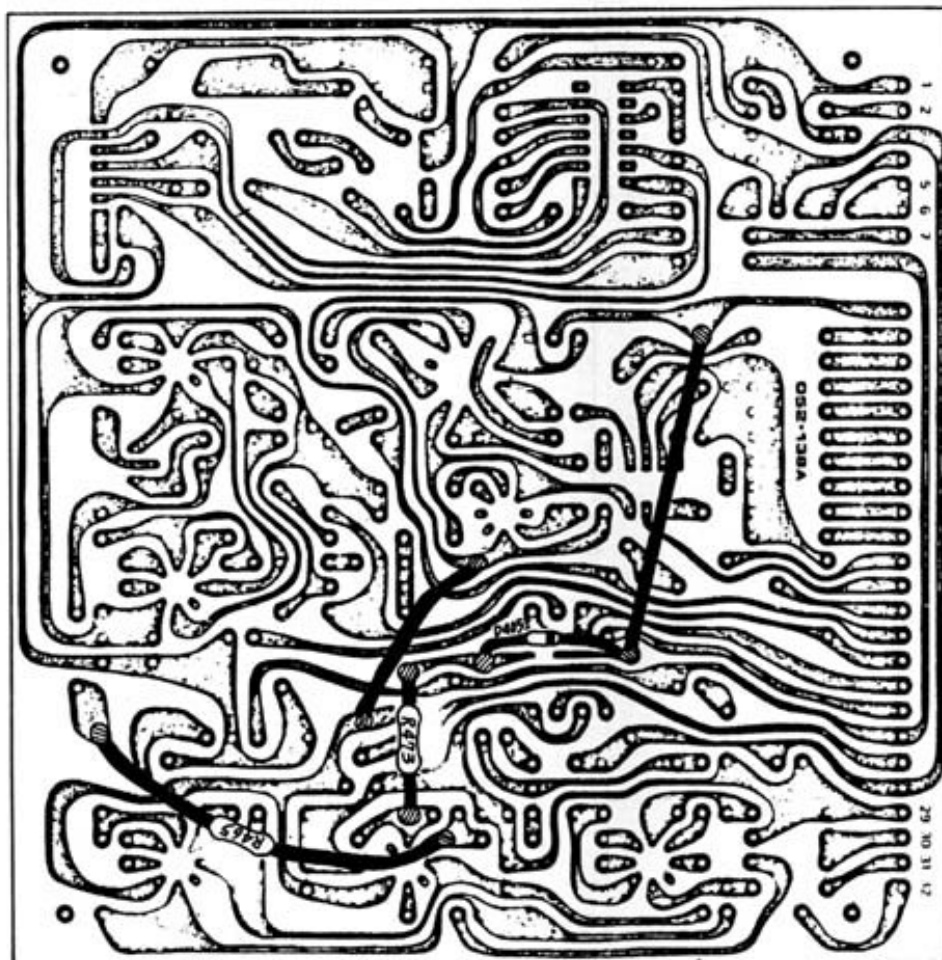
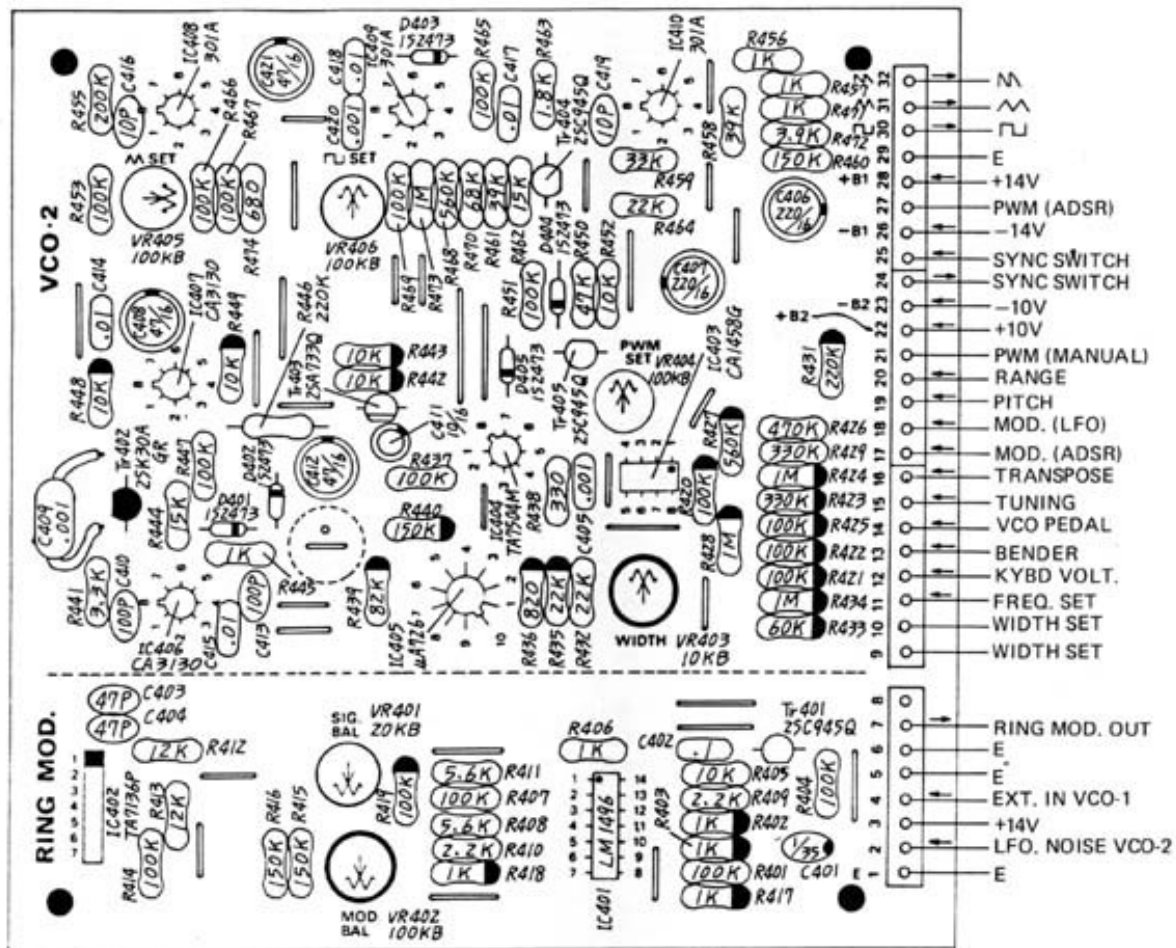

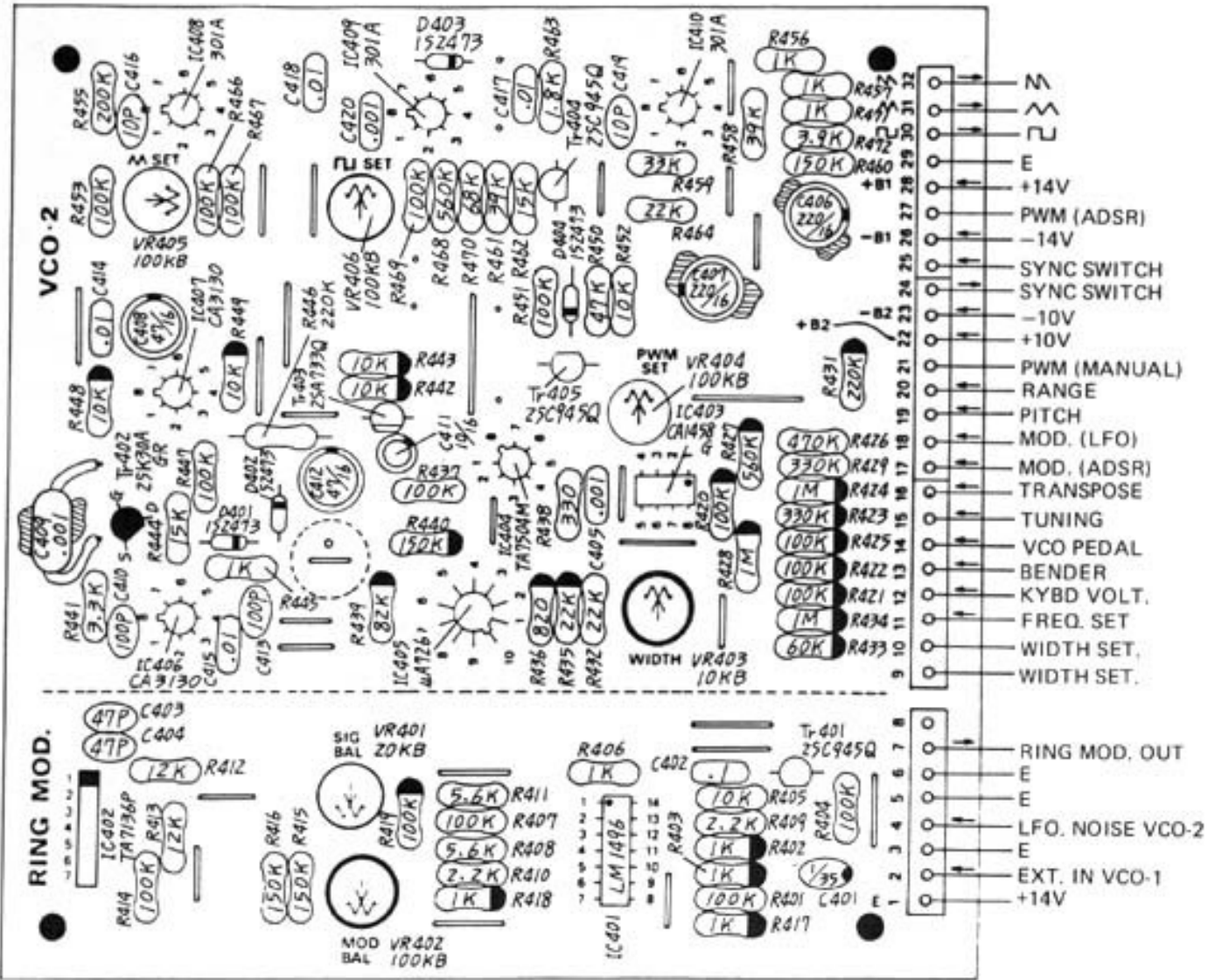

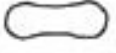
Serial No. 000400 and Higher

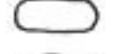

9-6. CIRCUIT BOARD ASSEMBLY OP-20A (149-020A) Serial No. Up to 440399





-  Metal Film Resistor CRB-1/4FX (1%)
-  Resistor 1/4R, J (5%)
-  Resistor ERC-12GK
-  Capacitor, Mylar (10%)
-  Capacitor, Ceramic (10%)
-  Capacitor, Tantalum (10%)
-  Capacitor, Electrolytic
-  Transistor 2SC945Q
-  Transistor 2SA733Q
-  Field Effect Transistor 2SK30A-GR
-  Diode 1S2473

9-7. CIRCUIT DIAGRAM (OP-20B) (VCO-2, Ring Mod)

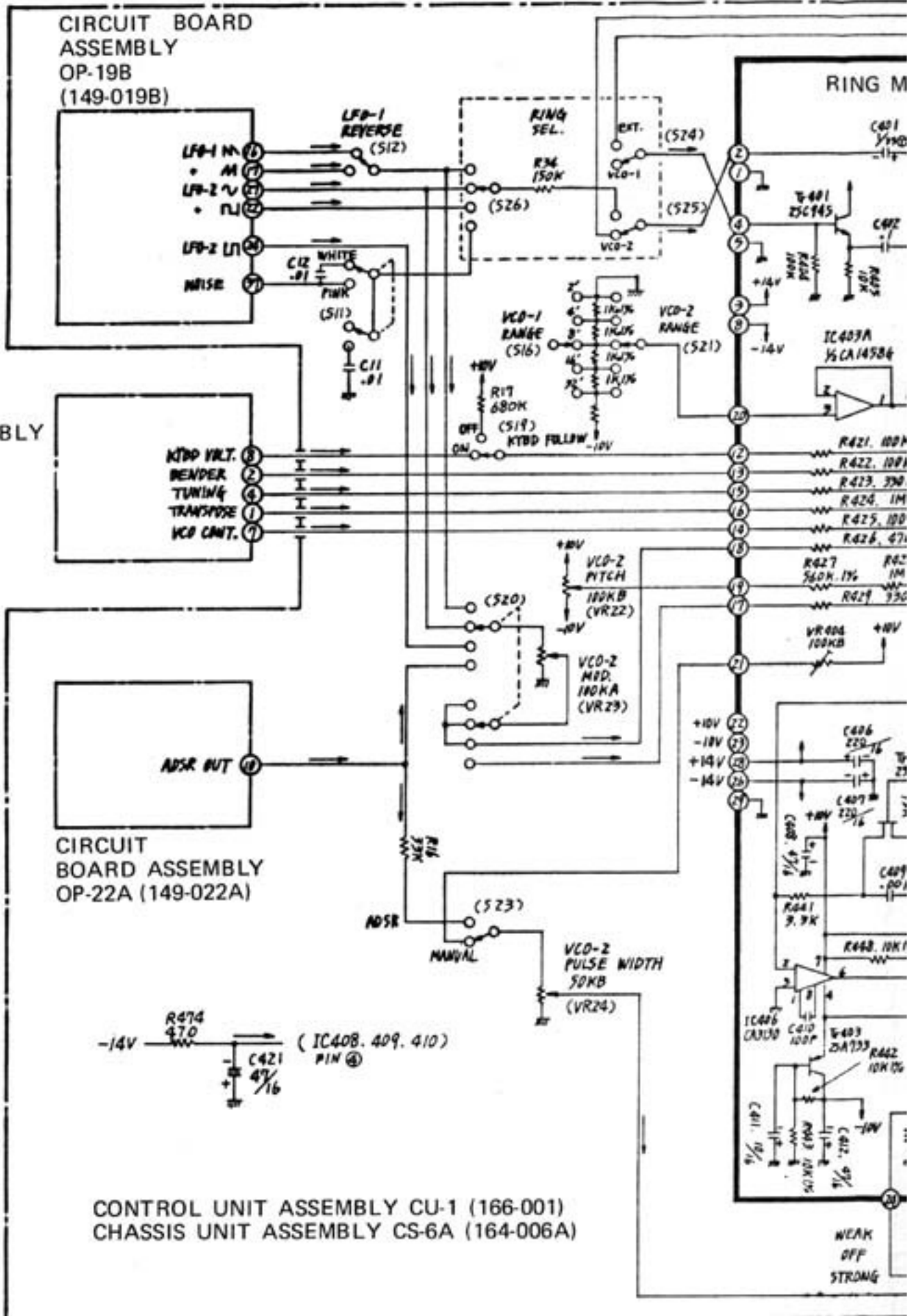

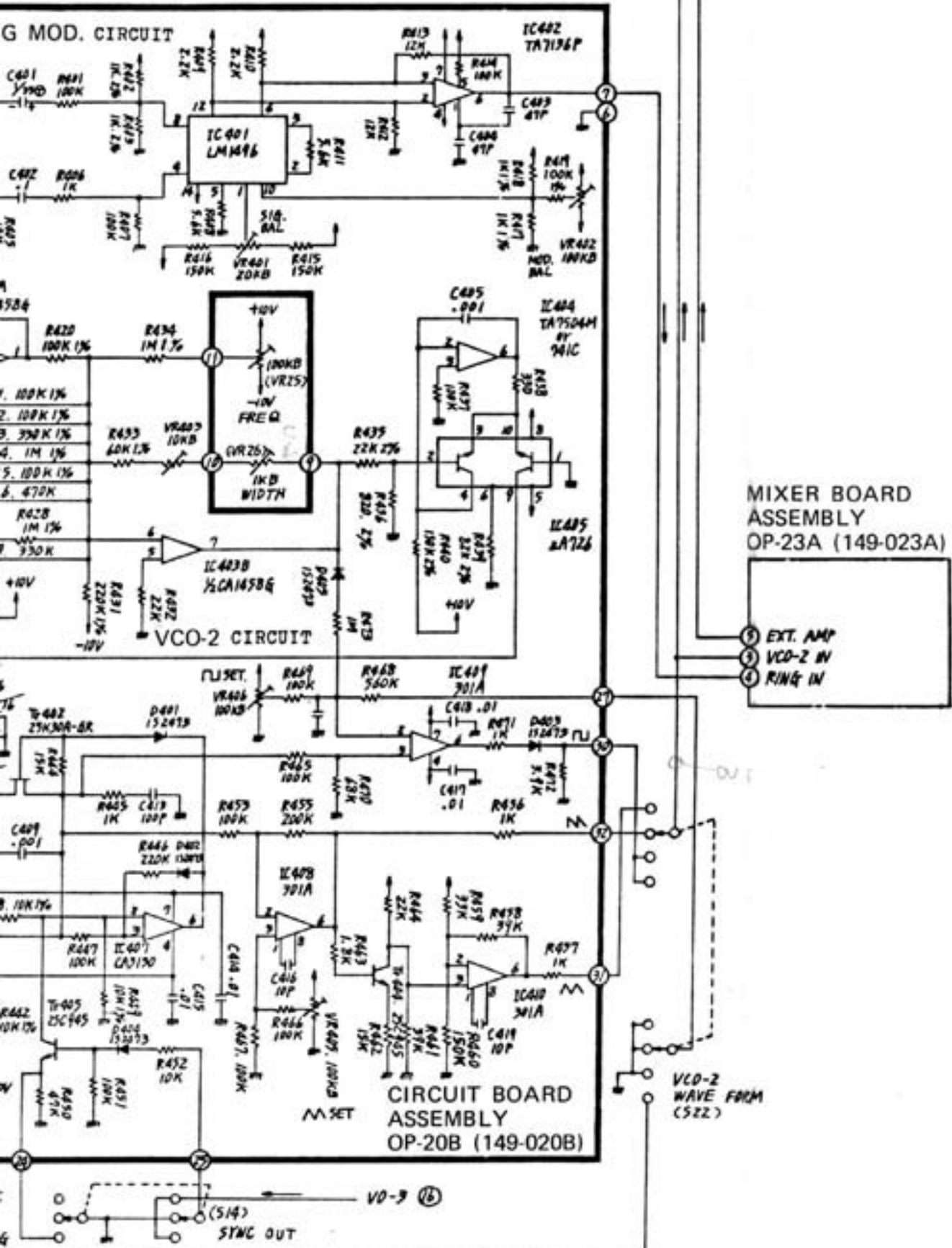

MIXER BOARD ASSEMBLY OP-23A (149-023A)

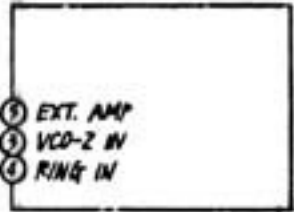

CIRCUIT BOARD ASSEMBLY OP-20B (149-020B)





VCO-2 WAVE FORM (522)

SYNC OUT (514)

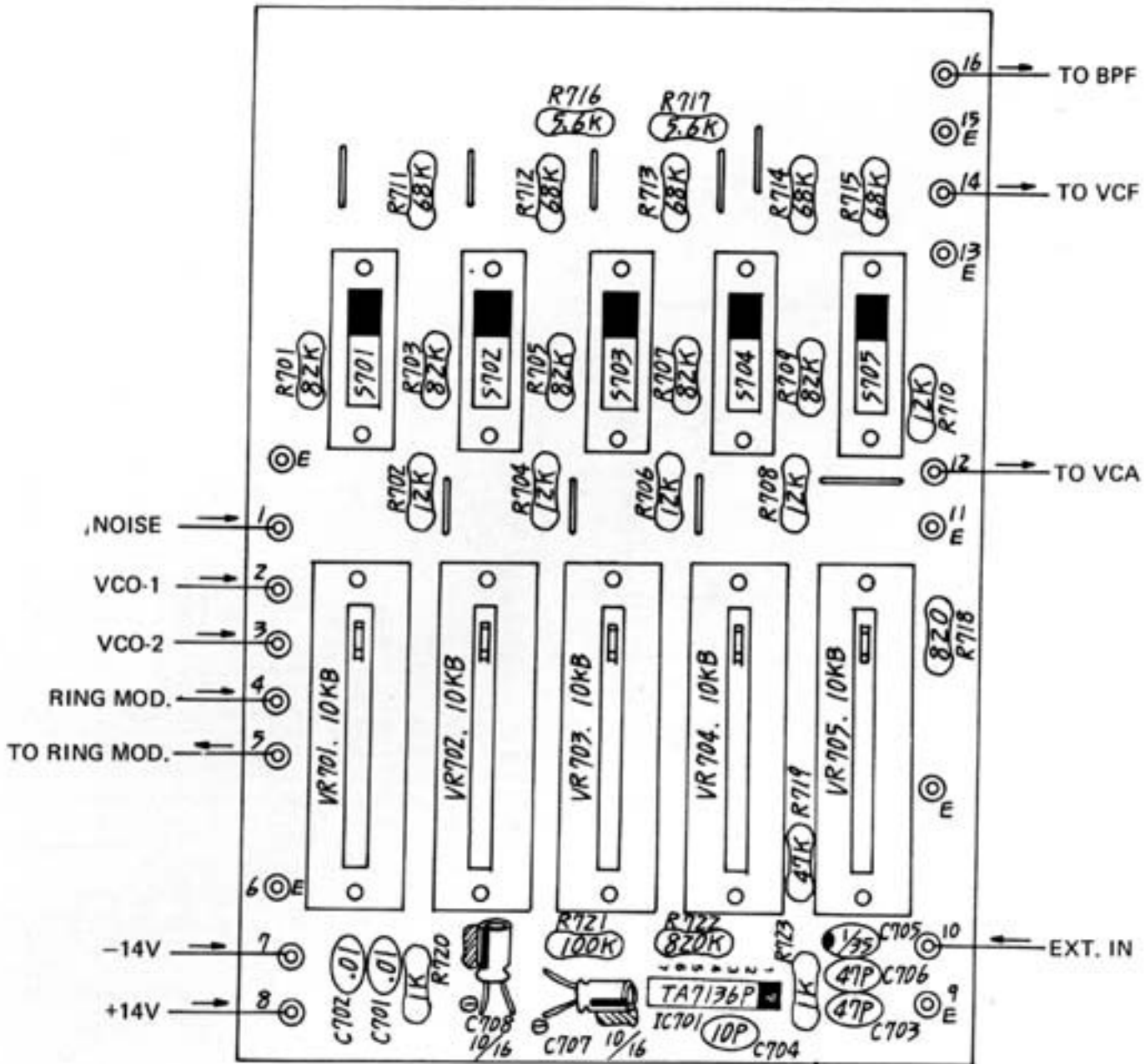
V0-9 (16)

9-8. MIXER BOARD ASSEMBLY OP-23A (149-023A)



-  Resistor 1/4R, J (5%)
-  Capacitor, Mylar (10%)
-  Capacitor, Ceramic (10%)
-  Capacitor, Tantalum (10%)
-  Capacitor, Electrolytic

9-9. CIRCUIT DIAGRAM (OP-23A) (Mixer. Ext. Amp.)

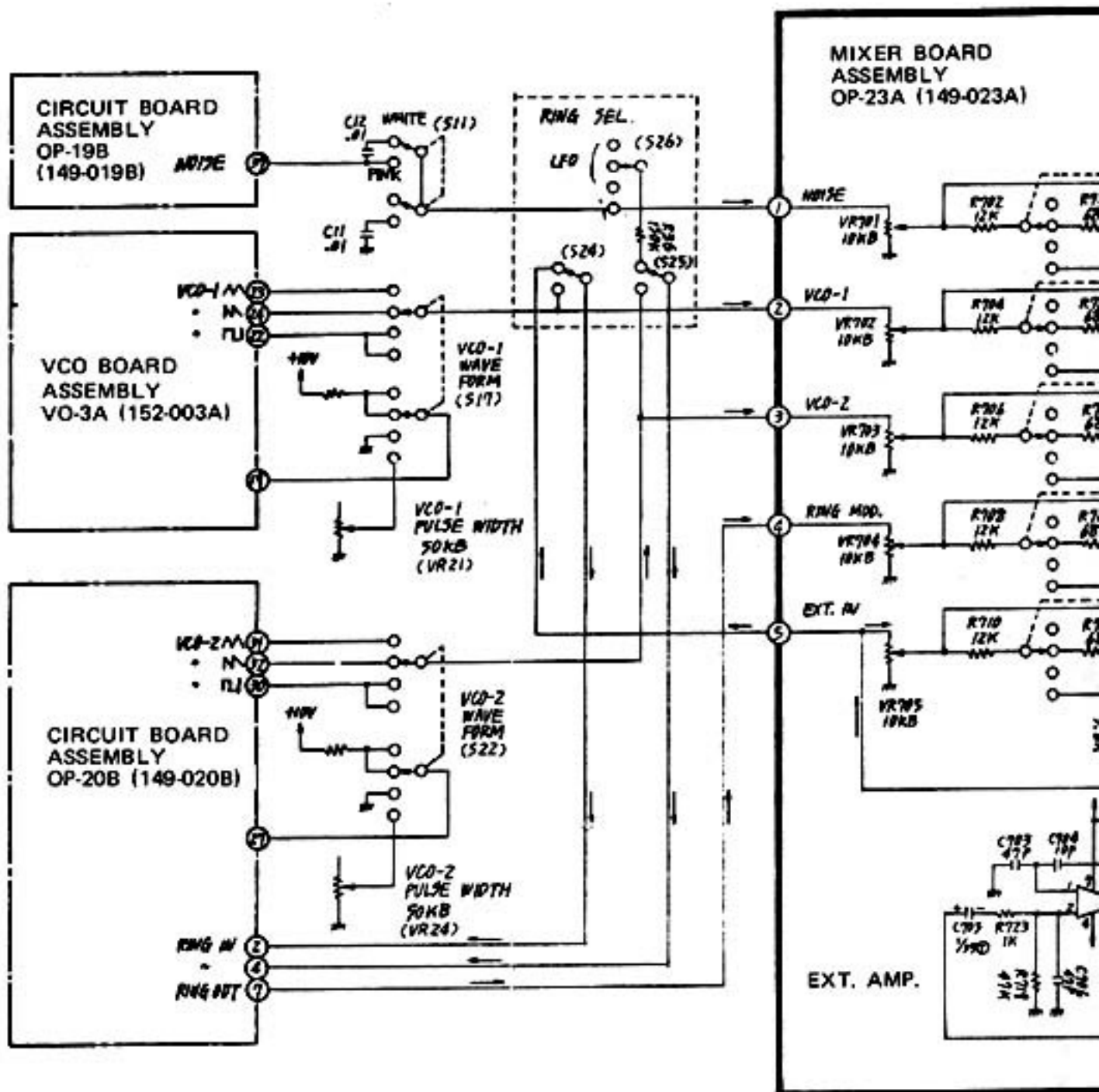

CONTROL UNIT ASSEMBLY CU-1 (166-001)
 CHASSIS UNIT ASSEMBLY CS-6A (164-006A)

1976-10-30 SH-5

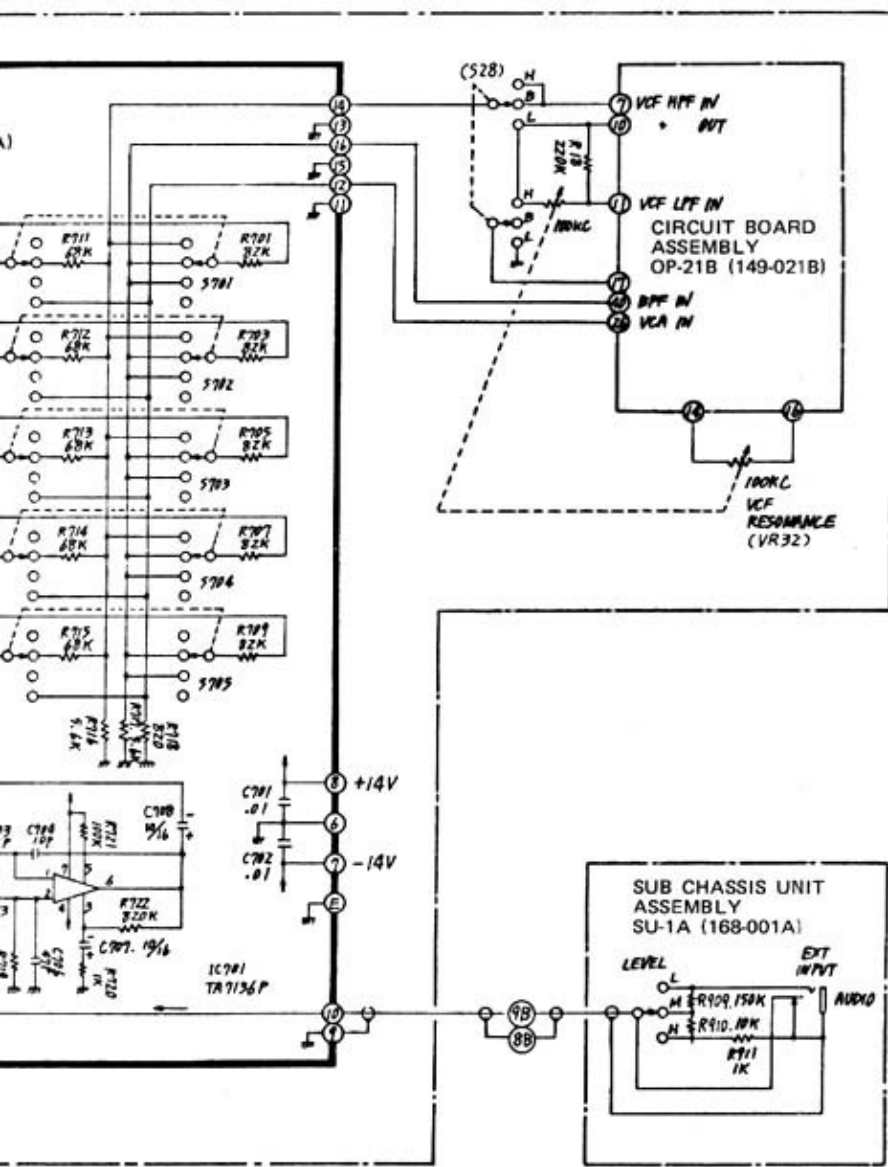

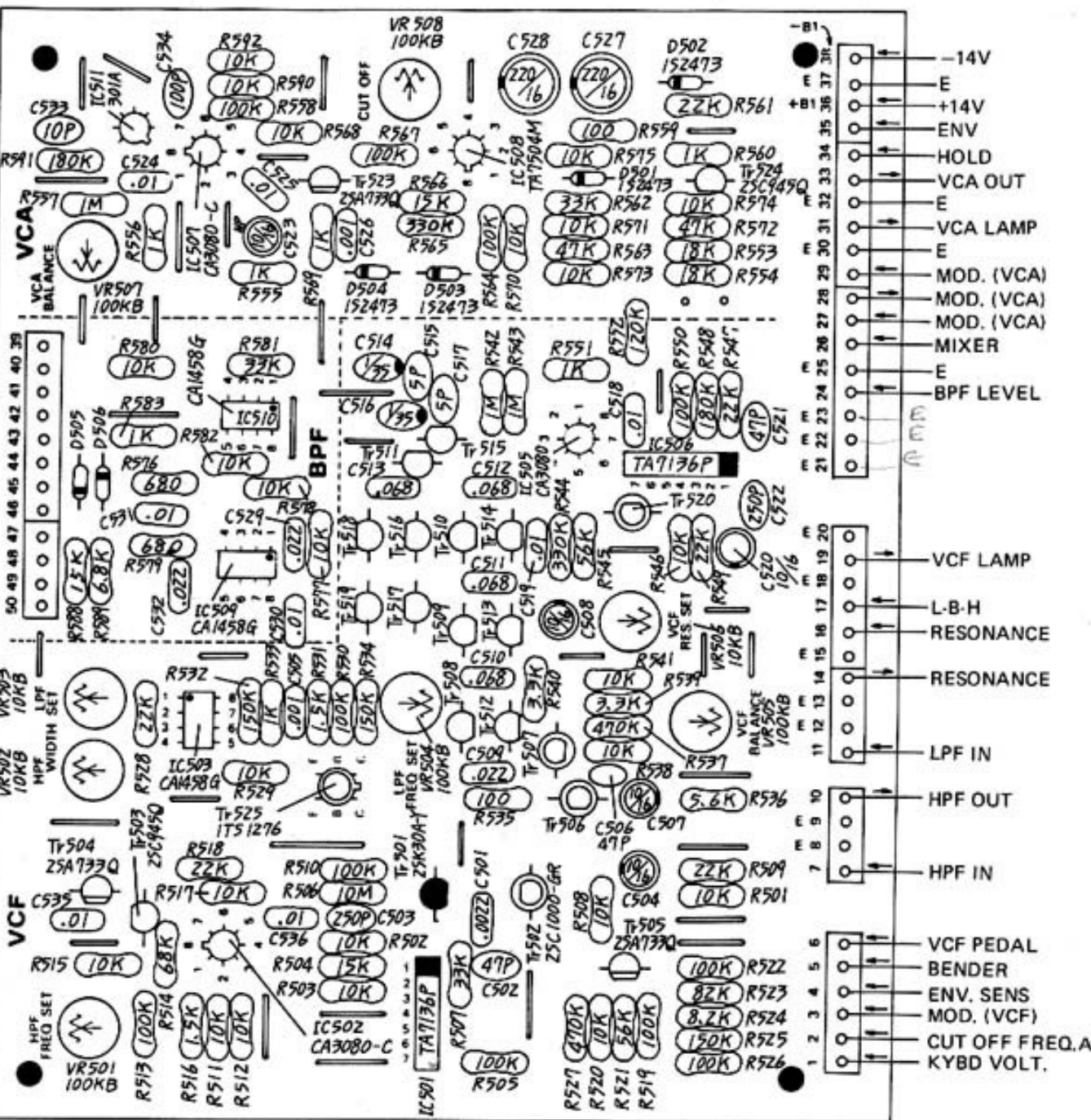

- Resistor 1/4R, J (5%)
- Resistor ERC-12GK
- Capacitor, Mylar (10%)
- Capacitor, Ceramic (10%)
- Capacitor, Tantalum (10%)
- Capacitor, Electrolytic
- Transistor 2SC945Q
- Transistor 2SA733Q
- Field Effect Transistor 2SK30A-GR
- Diode 1S2473

Tr516 . . . Tr 519 2SC945Q Roland selected VCF

Tr506 . . . Tr 507 2SC1000GR Roland selected VCF

9-11. CIRCUIT DIAGRAM (OP-21B) (VCF, VCA, Band Pass Filter)

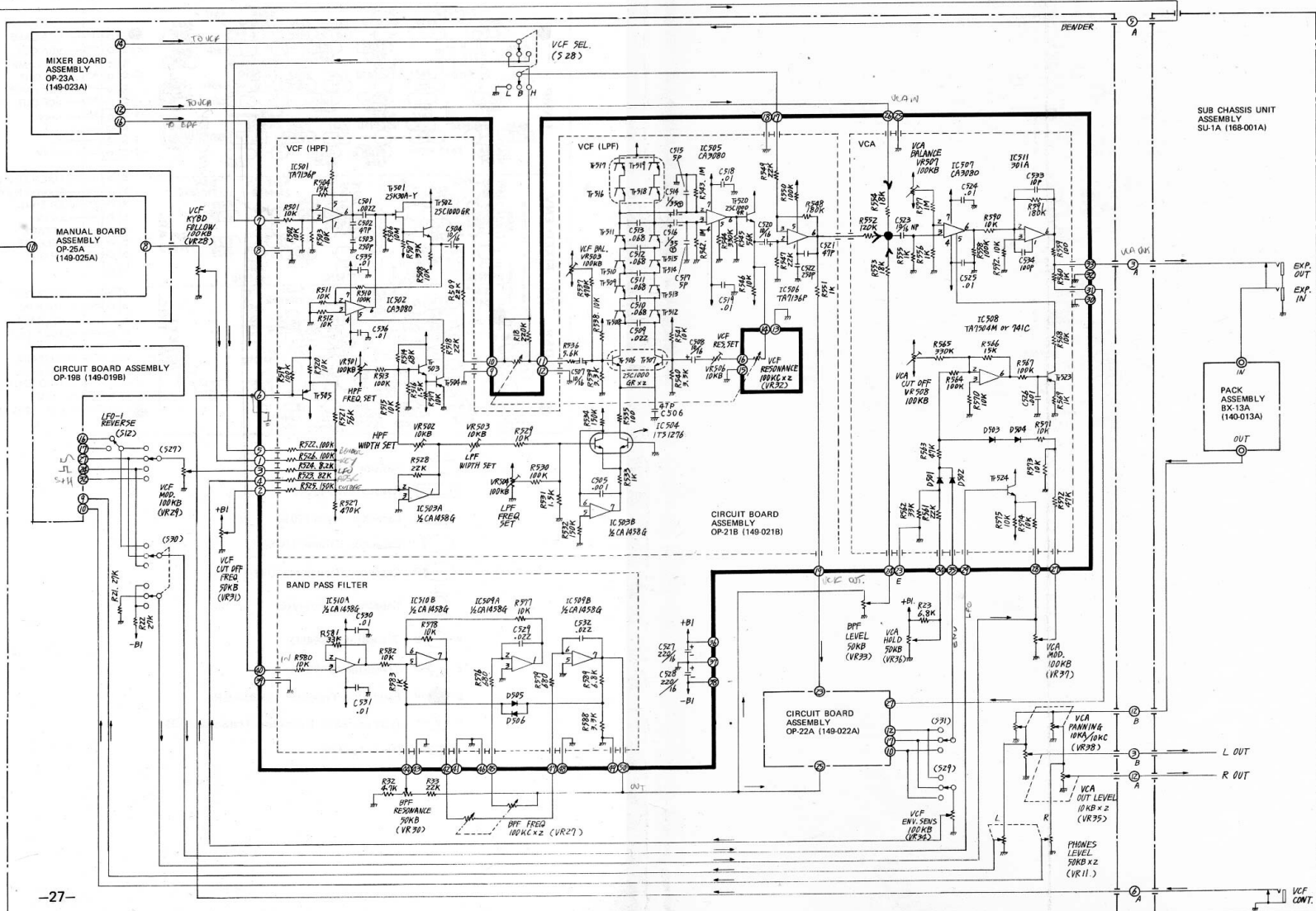

1976-10-30 SH-5

9-12. CIRCUIT BOARD ASSEMBLY OP-22 (149-022) Serial No. up to 440399

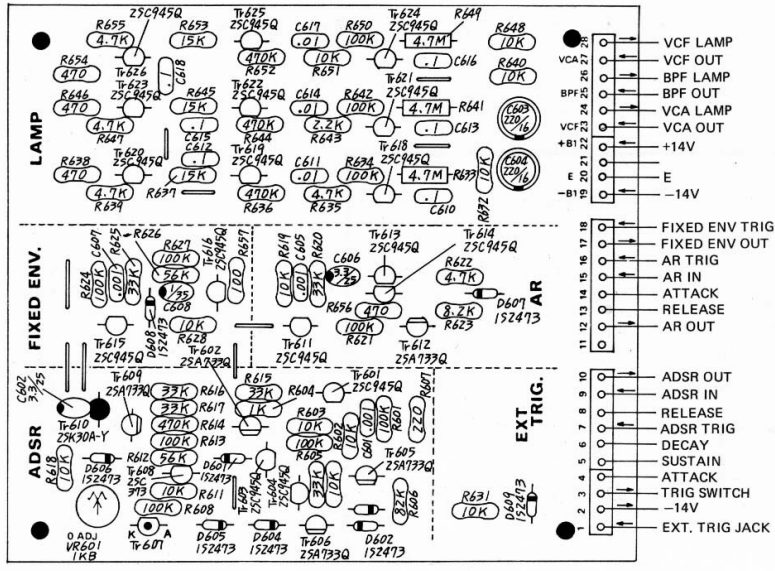

9-12a. CIRCUIT BOARD ASSEMBLY OP-22A (149-022A) Serial No. 450400 and Higher

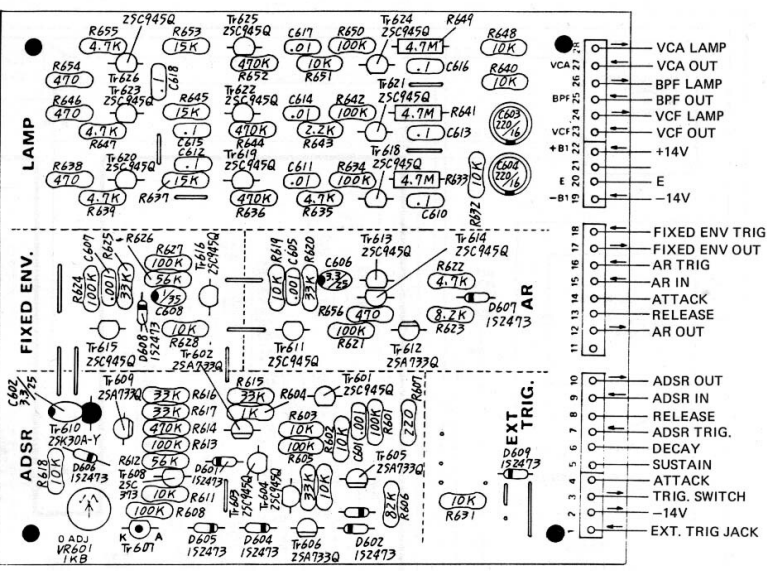

- Resistor 1/4R, J (5%)
- Resistor ERC-12GK
- Capacitor, Mylar (10%)
- Capacitor, Ceramic (10%)
- Capacitor, Tantalum (10%)
- Capacitor, Electrolytic
- Transistor 2SC945Q
- Transistor 2SA733Q
- Field Effect Transistor 2SK30A-GR
- Programmable Unijunction Transistor N13T1
- Diode 1S2473

9-13. CIRCUIT DIAGRAM (OP-22A) (AR, ADSR, Fixed Env. Lamp)

1976-10-30 SH-5

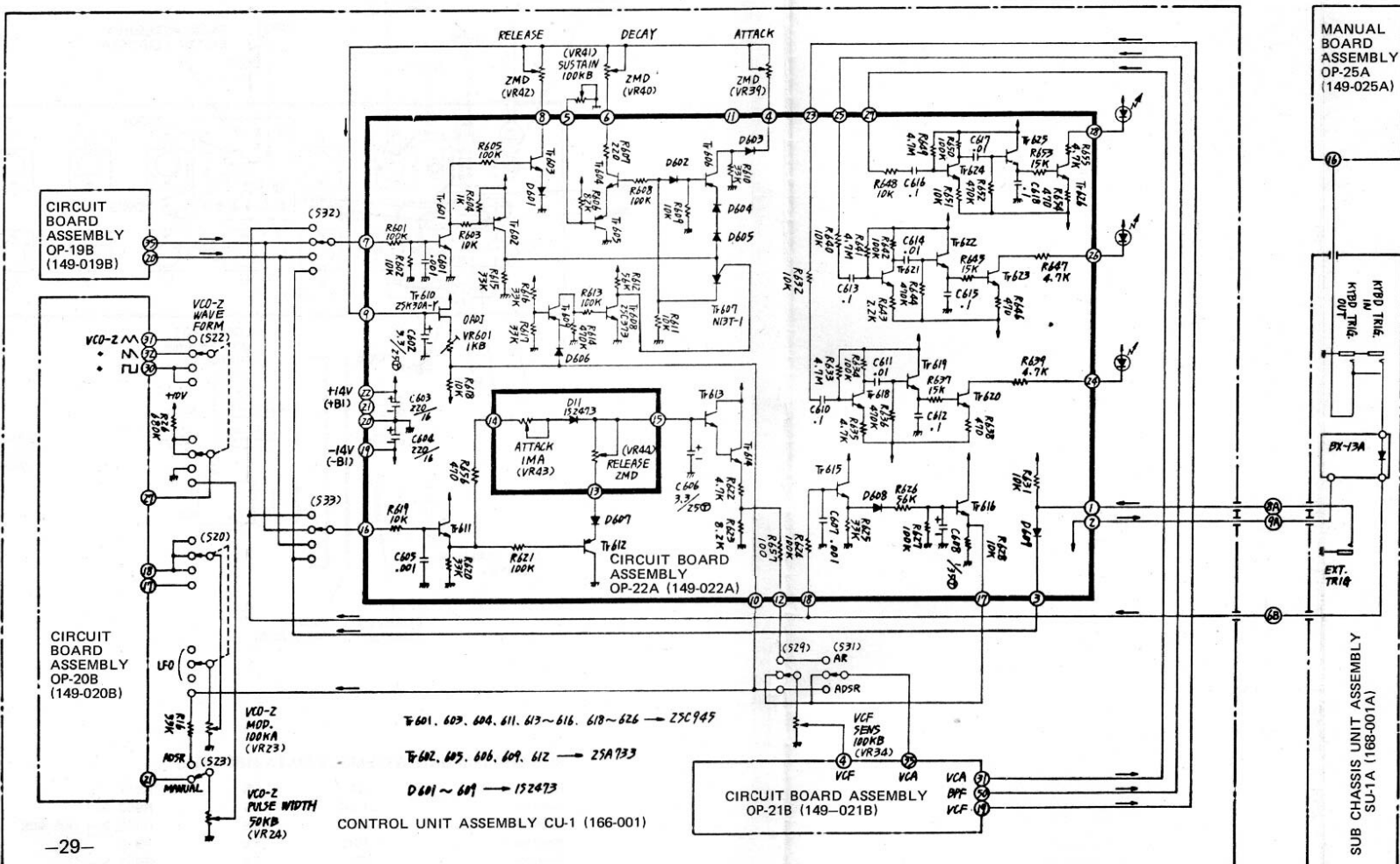

10. SUB CHASSIS UNIT ASSEMBLY SU-1A (168-001A)

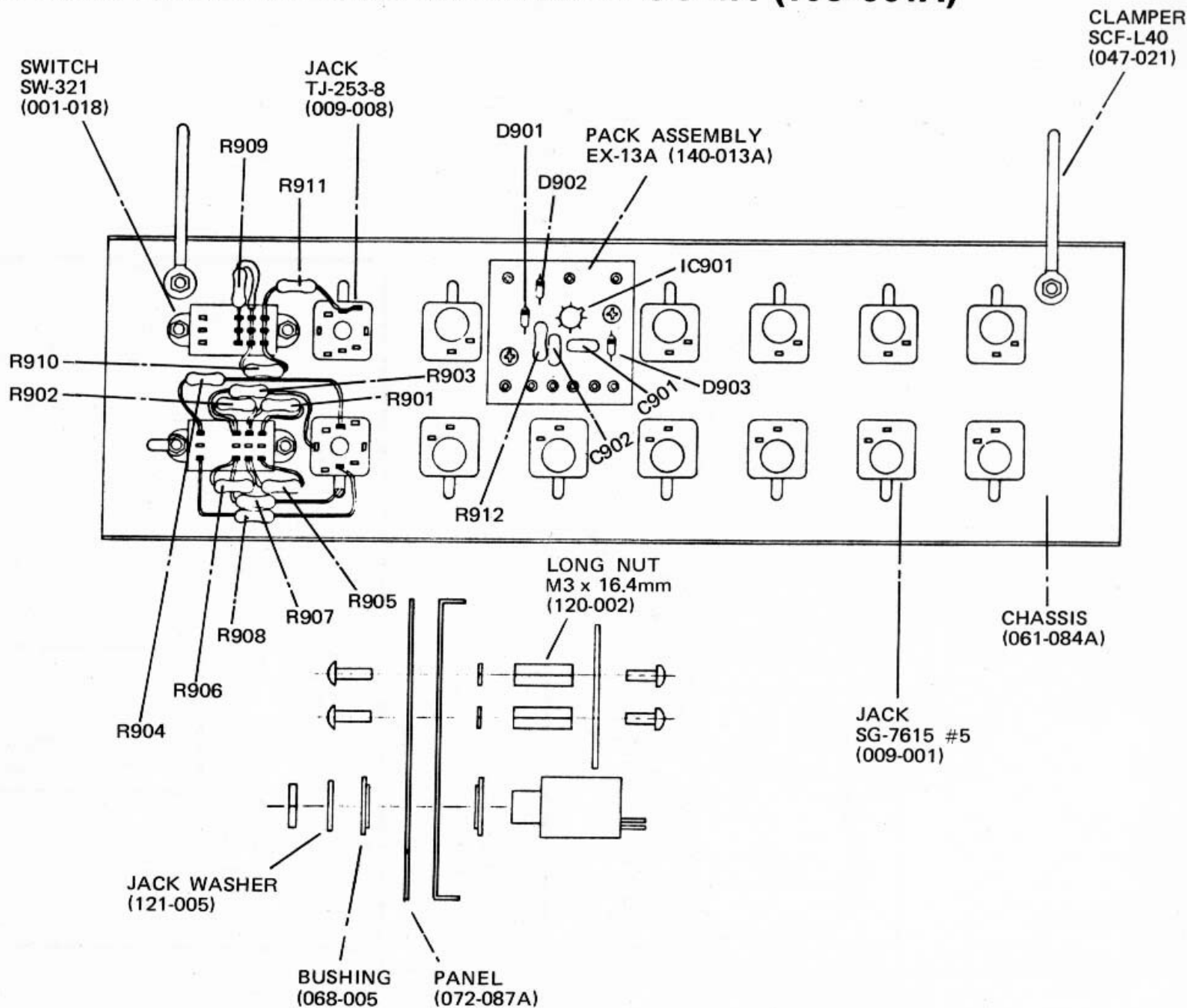

SUB CHASSIS UNIT ASSEMBLY SU-1A (168-001A)

Resistor	1K	5%	R911	044-037
Resistor	1.5K	5%	R903, 907	044-039
Resistor	4.7K	5%	R902, 904, 906, 908	044-044
Resistor	10K	5%	R910	044-048
Resistor	18K	5%	R901, 905	044-051
Resistor	150K	5%	R909	044-062

PACK BOARD ASSEMBLY BX-13A (140-013A)

Printed Circuit Board			052	052-175
IC	TA7504M		IC901	020-010
Diode	1S2473		D901, 902, 903	018-014
Resistor	10K	5%	R912	044-048
Capacitor, Mylar	.01 mf		C901, 902	035-016

10-1. CIRCUIT DIAGRAM (SU-1A) (BX-13A)

1976-10-30 SH-5

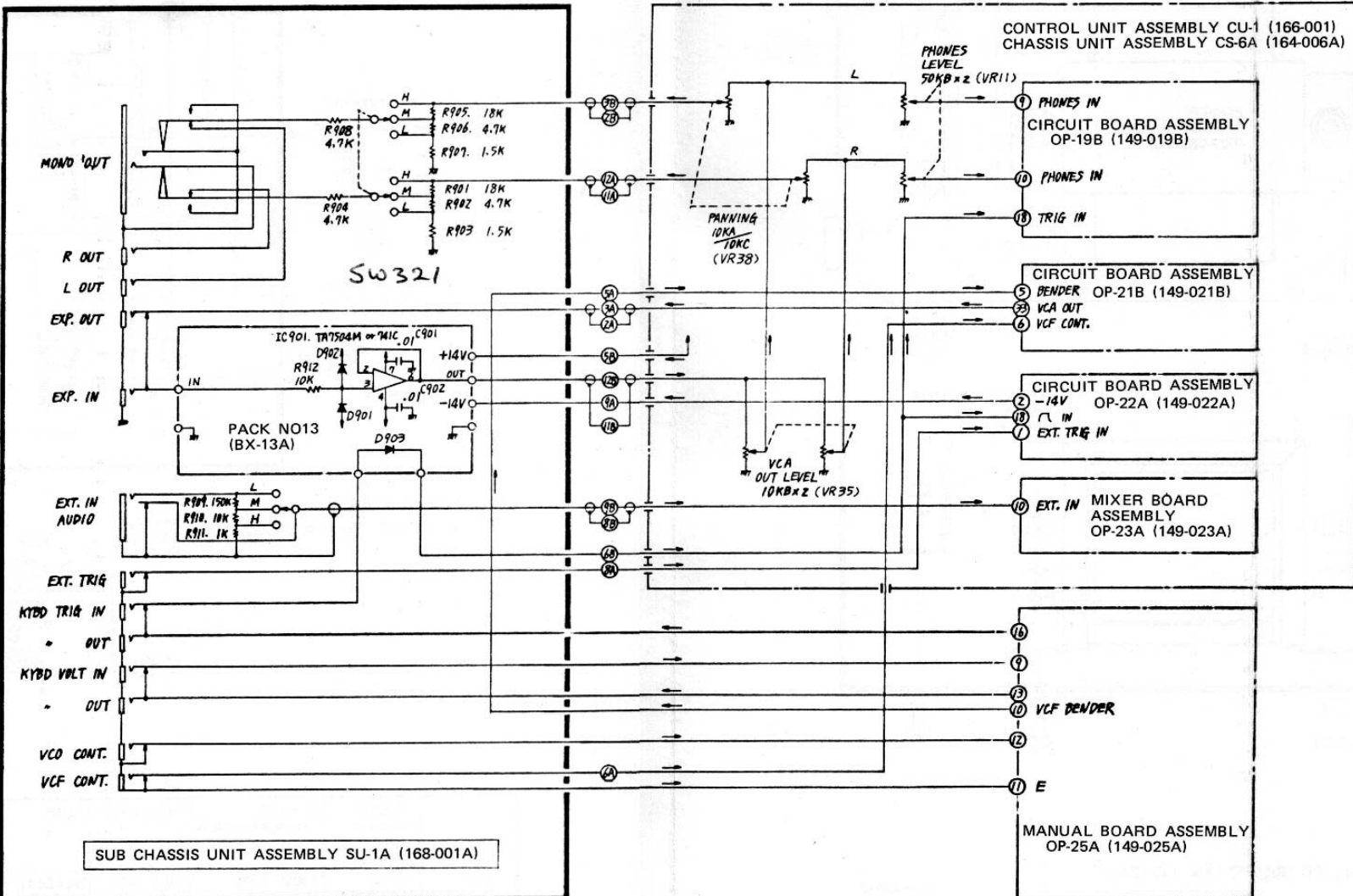

1976-10-30 SH-5

11. POWER SUPPLY UNIT ASSEMBLY PC-5A (162-005A)

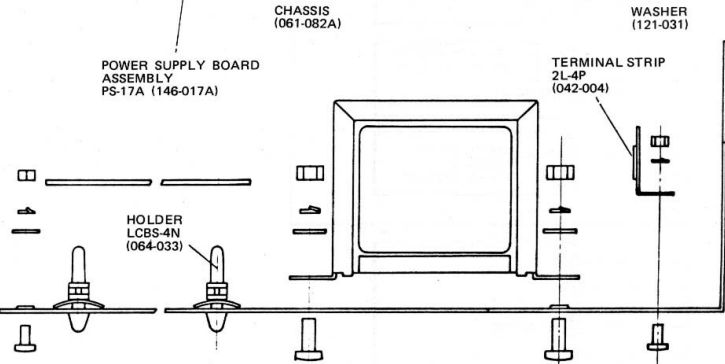
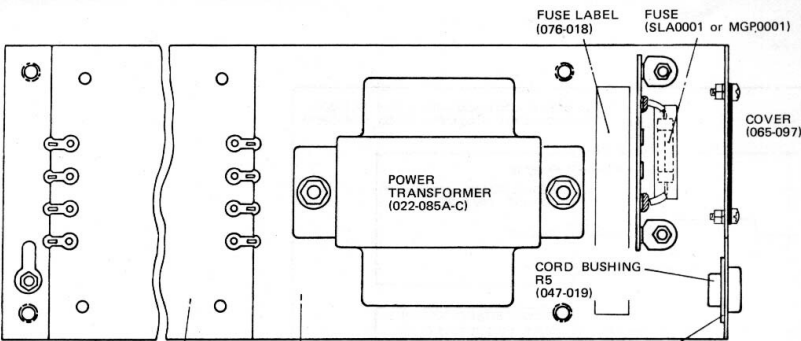

POWER SUPPLY UNIT ASSEMBLY (PC-9A, PC-10A, PC-11A, PC-12A)

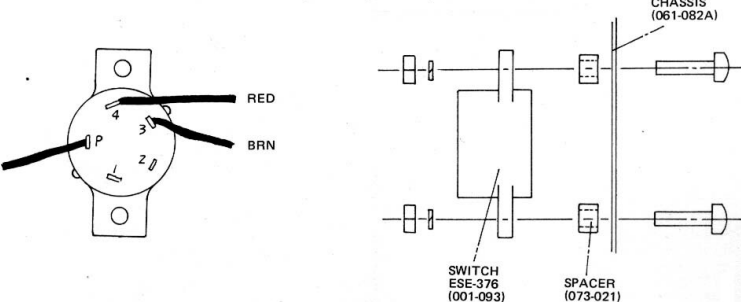

11-1. CIRCUIT DIAGRAM (PC-5A)

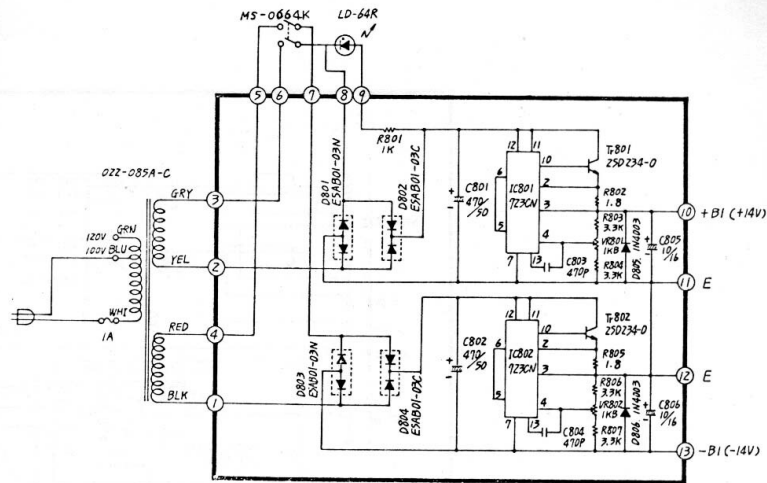

CIRCUIT DIAGRAM (PC9A, PC-10A, PC-11A, PC-12A)

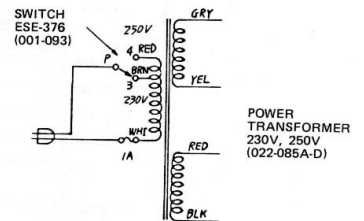

	POWER SUPPLY UNIT ASSEMBLY	POWER TRANSFORMER	AC CORD	FUSE	COVER 11, SPC-1 (065-097)	SWITCH ESE-376 (001-093)	SPACER (073-021)
100V	PC-5A (162-005A)	100V, 120V (022-085A-C)	SVT-2/18 KS-1, 3M (053-021)	SLA0001 (008-032)	○		
117V (UL, CSA)	PC-7A (162-007A)	100V, 120V (022-085A-C)	SVT-2/18 KS-1, 3M (053-021)	MGP0001 (008-041)	○		
117V	PC-8A (162-008A)	100V, 120V (022-085A-C)	SVT-3/18 KP-30, 3M (053-027)	MGP0001 (008-041)	○		
220V	PC-9A (162-009A)	230V, 250V (022-085A-D)	SVT-2/18 KS-1, 3M (053-021)	SLA0001 (008-032)		○	○
220V	PC-10A (162-010)	230V, 250V (022-085A-D)	VM0065 CEE, 3M (053-028)	SLA0001 (008-032)		○	○
240V	PC-11A (162-011A)	230V, 250V (022-085A-D)	SVT-2/18 KS-1, 3M (053-021)	SLA0001 (008-032)		○	○
240V	PC-12A (162-012A)	230V, 250V (022-085A-D)	MTSA-3 KP-550, 3M (053-026)	SLA0001 (008-032)		○	○

11-2. POWER SUPPLY BOARD ASSEMBLY PS-17A (146-017A)

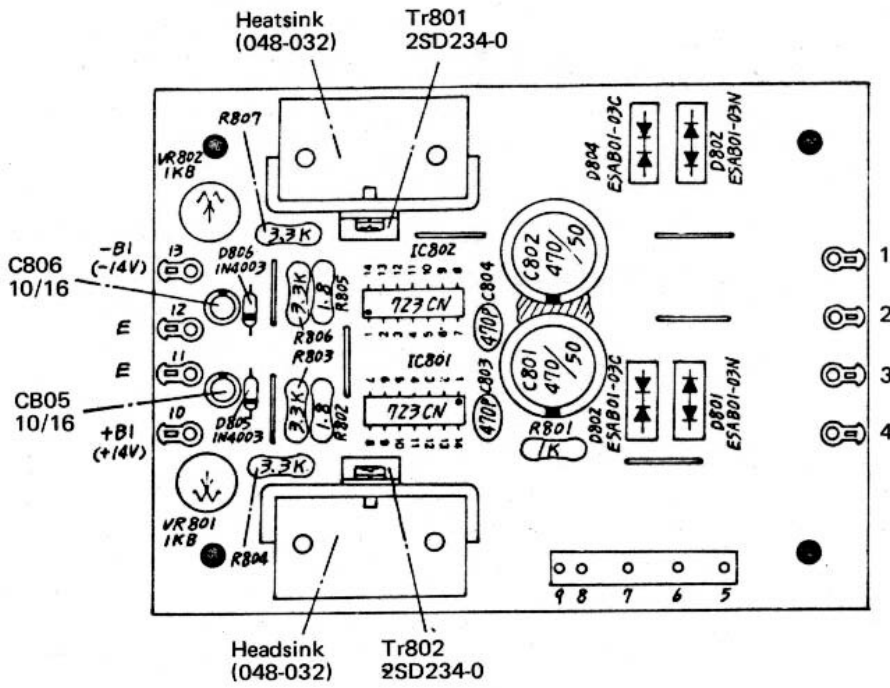

100V - 120V

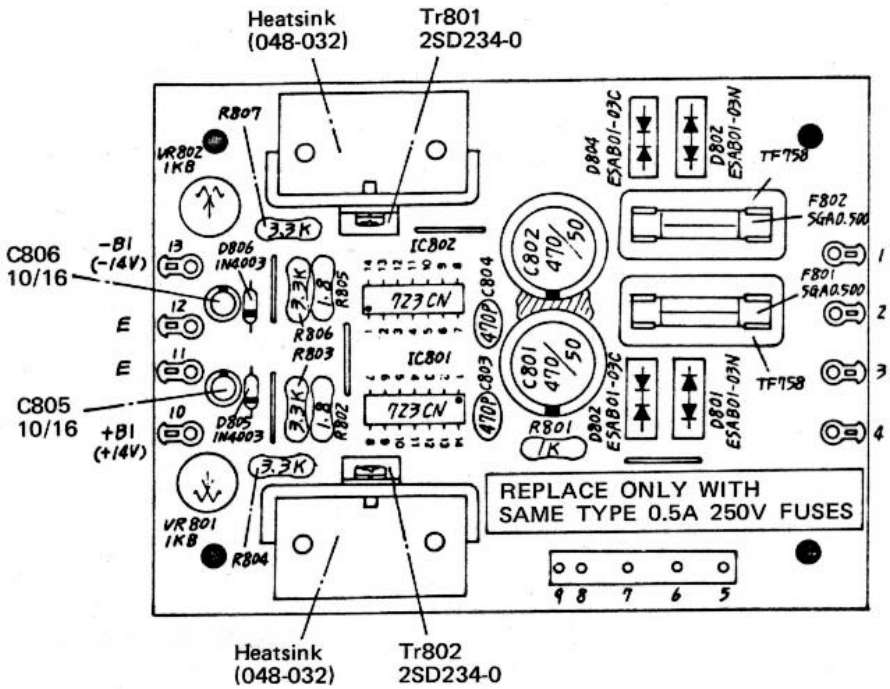

11-3. POWER SUPPLY BOARD ASSEMBLY PS-23A (146-023A)

200V - 250V



-  Resistor 1/4R, J (5%)
-  Capacitor, Ceramic (10%)
-  Capacitor, Electrolytic

CAUTION

Be sure to check the power supply voltages before troubleshooting or adjusting the following circuits.

$\pm 14V$: All circuits $\pm 10V$: KB-1, VCO-1, VCO-2,

The following equipment is necessary for adjustment:

- | | |
|-------------------|-------------------------------|
| Digital Voltmeter | Oscilloscope |
| Frequency Counter | Audio Generator |
| (Tuning Meter) | (Audio Amplifier and Speaker) |

Although not necessary, an audio amplifier and speaker can be very convenient when making adjustments.

All ground connections for test equipment can be made at Terminal 6 (black) on the OP-19 circuit board, or to any terminal with a grounded shield connection.

Be sure all front panel controls are set as shown in the drawings before making adjustments.

Make sure that slide switches on the front panel are not set between positons as this will upset adjustments.

For potentiometer adjustments, right means clockwise and left means counterclockwise.

Pressing a key on the keyboard establishes the control voltage for that key at the VCO. This voltage will remain after release of the key, but due to leakage, the VCO frequency will gradually drift downwards. For this reason, all measurements and adjustments related to the keys should be done while holding the related key down. A small lead weight may prove useful.

12-1 ± 14 VOLT adjustment

Adjust VR-801 for +14 volts, $\pm 100mV$.

Adjust VR-802 for -14 volts, $\pm 100mV$.

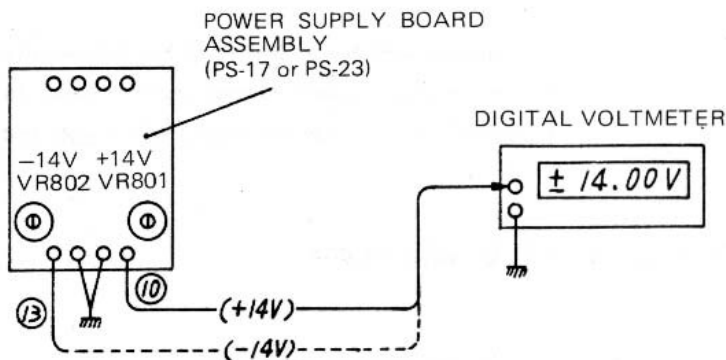

12-2 ± 10 VOLT adjustment

Adjust VR-201 for +10 volts, $\pm 5mV$

Adjust VR-202 for -10 volts, $\pm 5mV$.

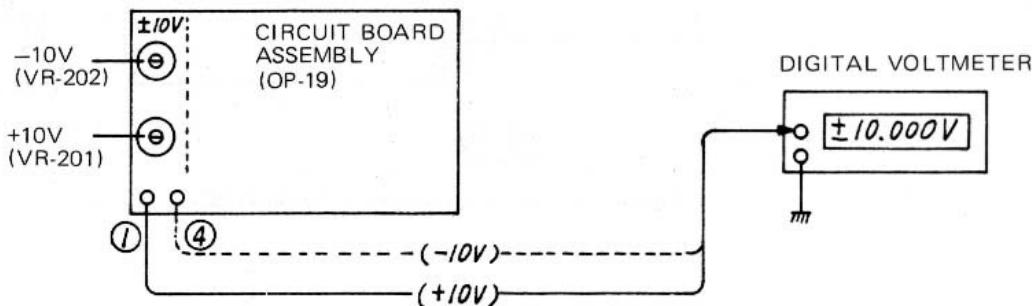

12-2-2 LFO-1 Adjustment

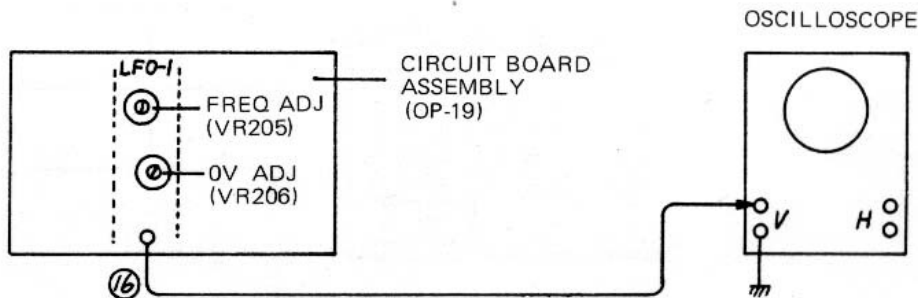

1976-10-30 SH-5

Turn VR-206 all the way left; then turn right until sawtooth just clears cutoff point.

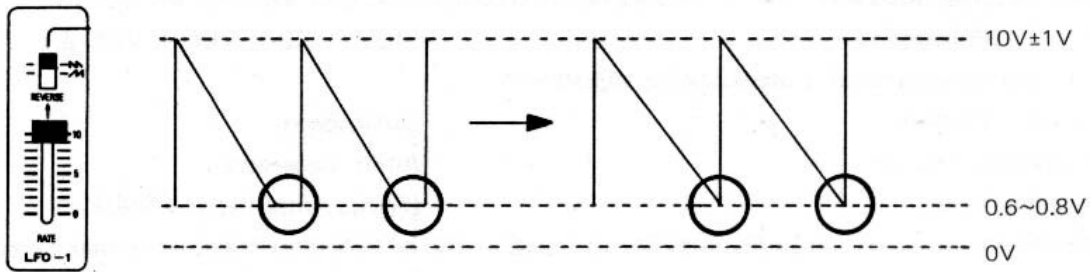

Set VR-205 for 1 cycle = 10 seconds

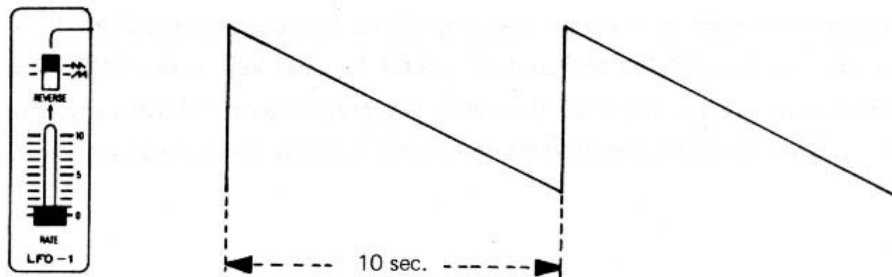

The easiest way to do this is to set the oscilloscope for no horizontal sweep; use a stop watch or wrist watch sweep second hand to time the fall of the dot on the screen. (Tapping a key on the key-board will trigger the LFO).

12-2-3 SAMPLE & HOLD adjustment

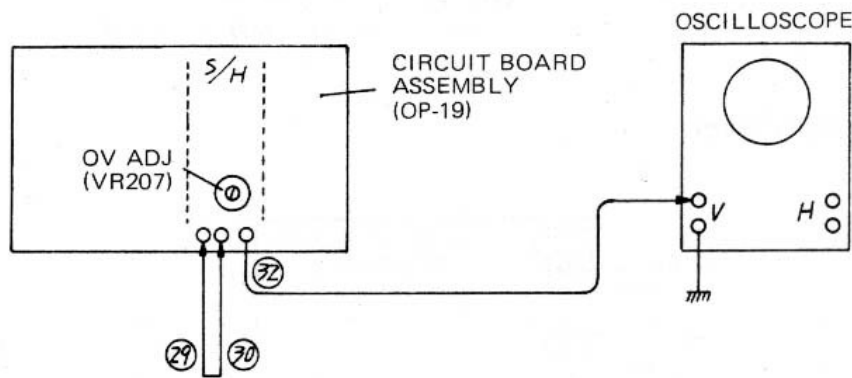

Short Terminal 29 to ground (Terminal 30)

Adjust VR-207 for 0 volts.

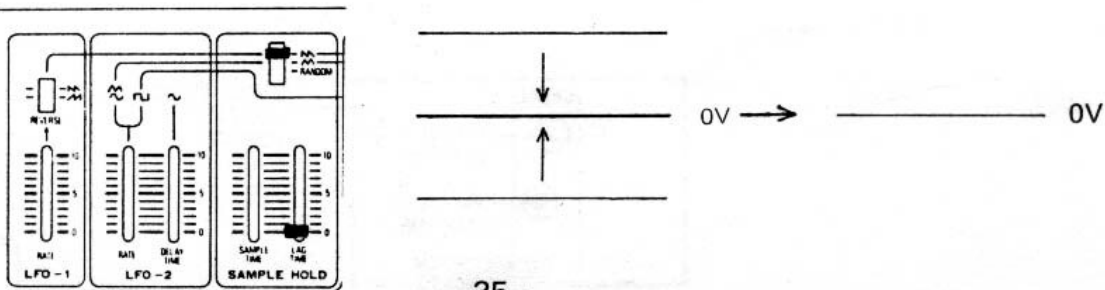

12-2-4 NOISE GENERATOR adjustment

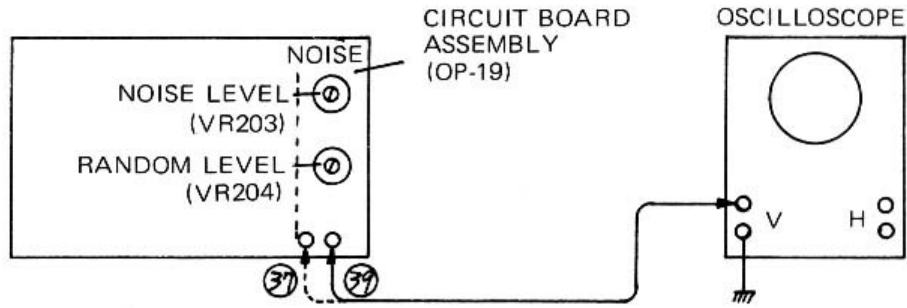

Adjust VR-203 for:

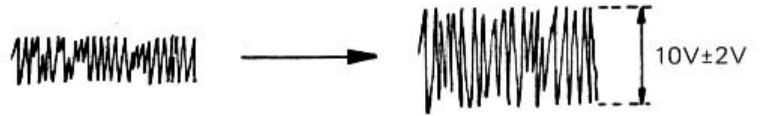

Adjust VR-204 for:

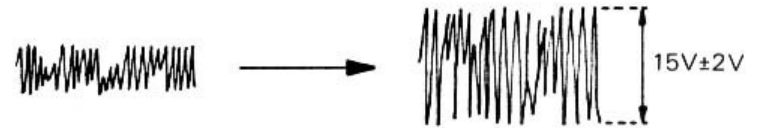

12-3 KB-1 KEYBOARD adjustments

12-3-1 KEY VOLTAGE

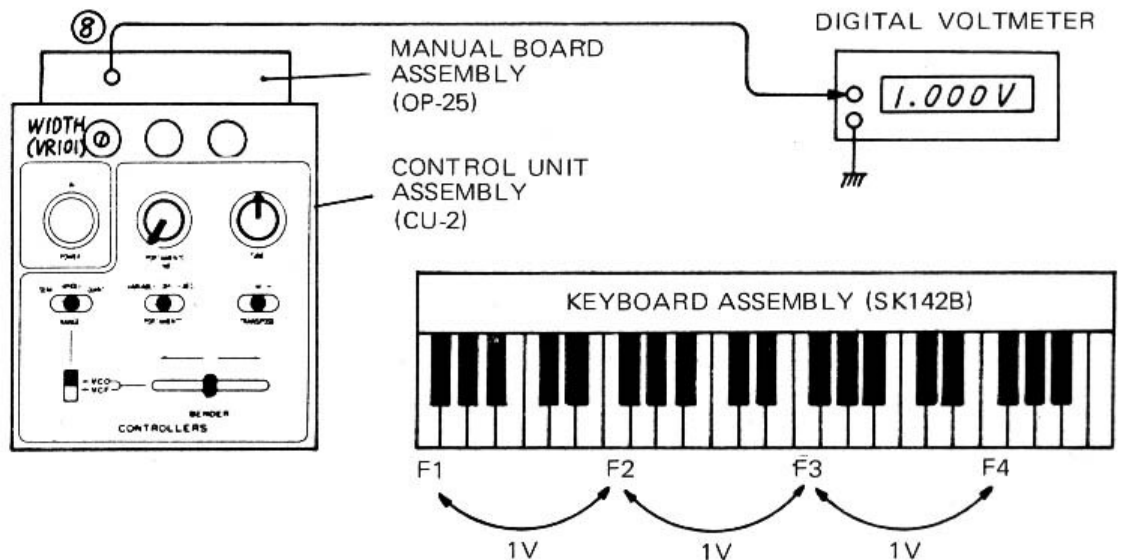

Press F1 key, note voltage, call it "X". Press F4 key, set VR-101 for X +3.00V (±1mV)
 Confirm that F2 key produces X +1.00V; F3 = X +2.00V

12-3-2 BENDER VOLTAGE adjustment

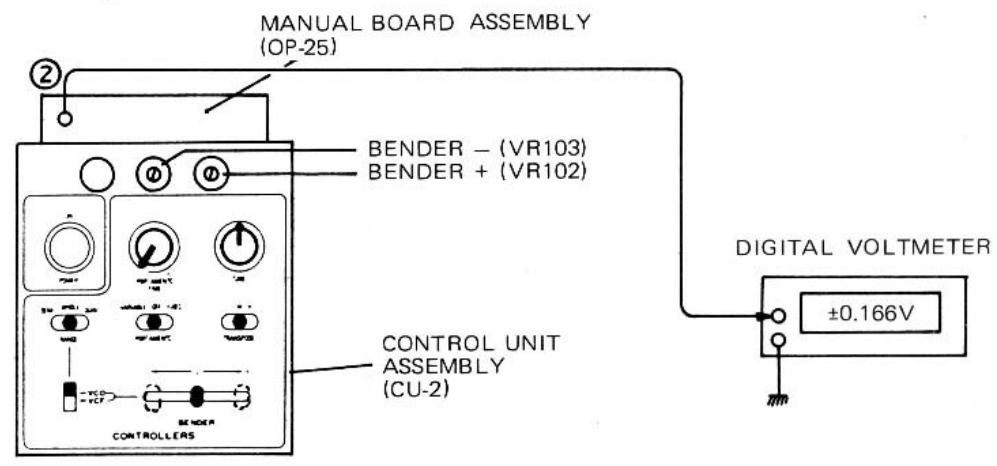

Push BENDER lever all the way to the right (+); set VR-102 for $+0.166V. \pm 2mV$.
 Push BENDER lever all the way to the left (-); set VR-103 for $-0.166V. \pm 2mV$.

12-4 VO-3

CAUTION:

Be sure to check the power supply voltages before adjustment. Allow at least 3 minutes as a warm up period.

12-4-1 VCO RANGE SET

Adjust VR-305 for $-4V \pm 1mV$
 (Applicable to serial No. 500950 and Higher.)

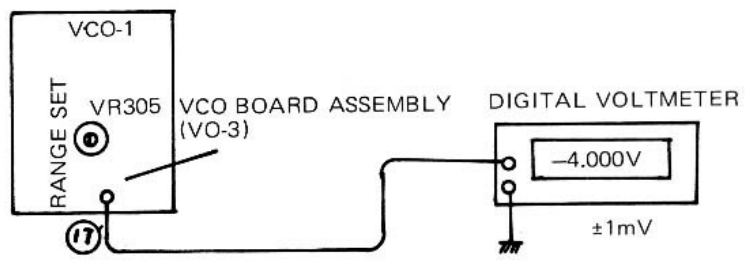

12-4-2 VCO-1, Δ Adjust

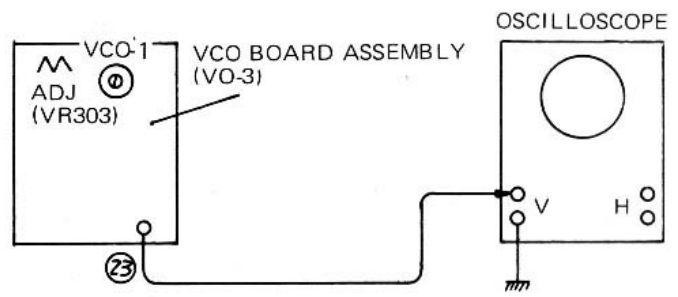

Adjust VR-303 for:

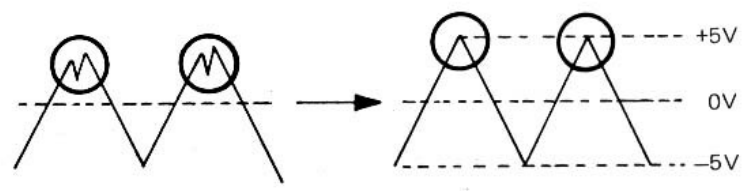
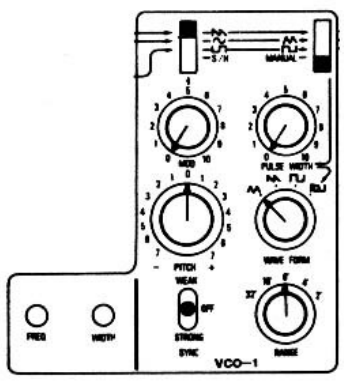

12-4-3 VCO-1, \square adjust

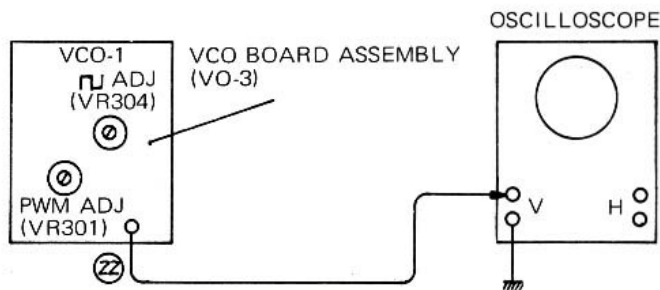

Adjust VR-304 for:

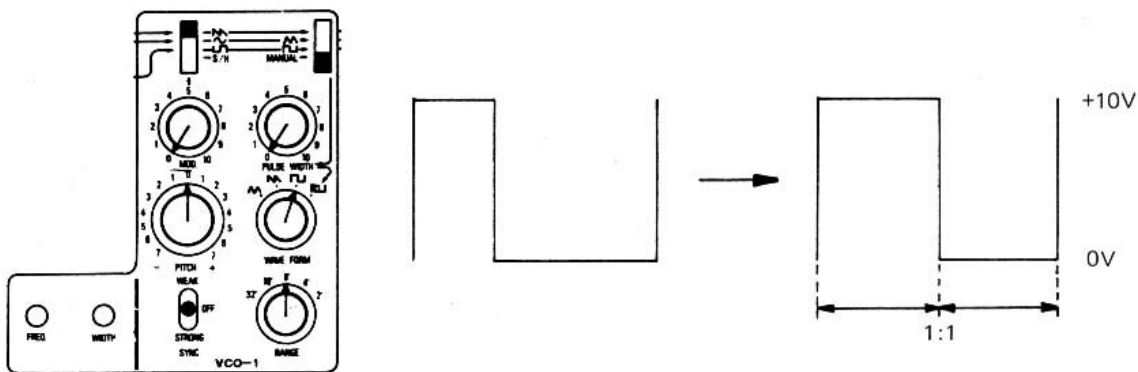

Adjust VR-301 for:

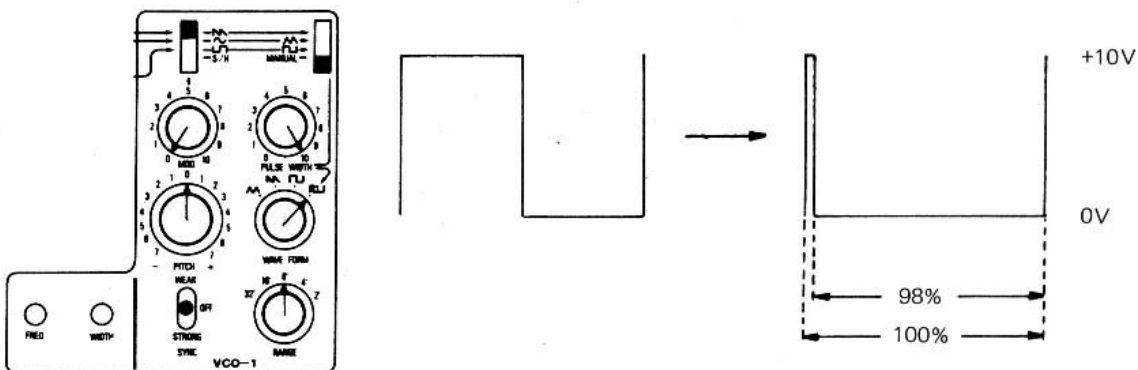

12-4-4 VCO-1 FREQUENCY WIDTH

Press F1 and adjust for some convenient reading (such as 100); call this "X". Check that F2 produces 2X; F3 = 4X; and F4 = 8X.

If F4 is not within ± 1 Hz., VCO WIDTH needs adjusting.

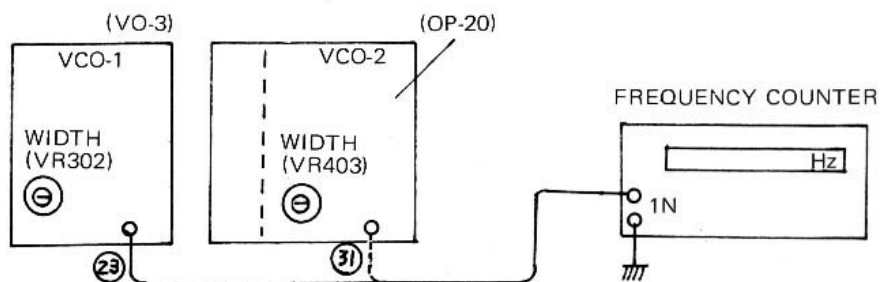

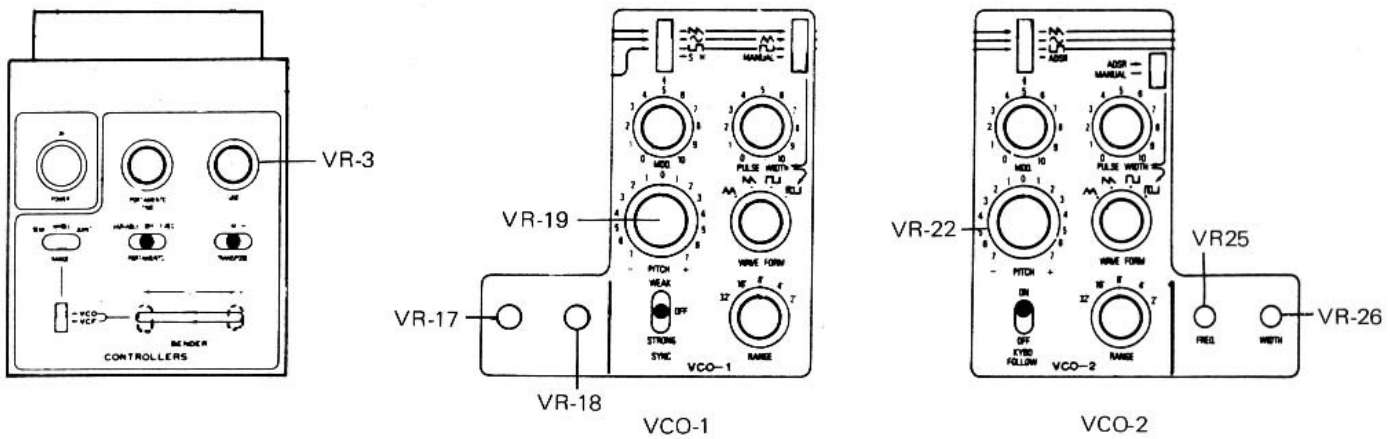

There are three potentiometers which control the frequency output of each of the VCO's:

Name	Location	Number		Value
		VCO-1	VCO-2	
PITCH	Front panel	VR-19	VR-22	100k Ω
FREQ	Front panel	VR-17	VR-25	
TUNE	CONTROLLERS	VR-3		

There are two WIDTH potentiometers for each VCO:

Name	Location	Number		Value
		VCO-1	VCO-2	
WIDTH	Front panel	VR-18	VR-26	1k Ω
WIDTH SET VR	VO-3	VR-302	—	10k Ω
	OP-20B	—	VR-403	10k Ω

Since a change in the WIDTH controls changes all frequency relationships on the keyboard, the frequency controls can be set at any convenient point for the WIDTH adjustments

Set the PITCH, FREQ, and TUNE controls at center.

There are three methods which can be used for setting the VCO WIDTH

TUNING METER METHOD

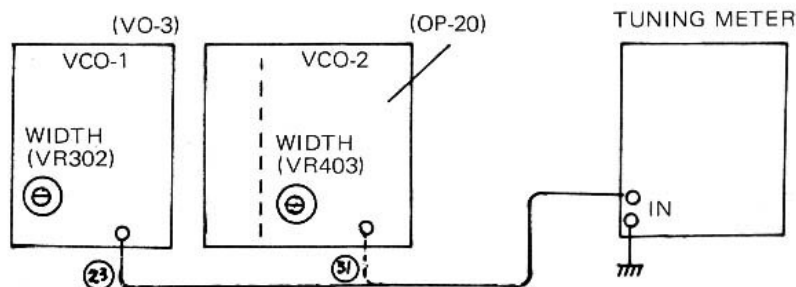

Press F1; select proper pitch on tuning meter and adjust FREQ-control (VR-17), for unison

Press F2; note whether it is sharp or flat.

If sharp, turn VR-302 so pitch becomes a little sharper. If flat, turn VR-302 so pitch becomes a little flatter.

Press F1; adjust VCO frequency (VR-17) for unison.

Repeat the above steps until F1 and F2 are in tune.

- NOTE: 1. If during the procedures the TUNE control goes all the way to the stop, reset it at center and use the FREQ control once; then use the TUNE again in successive steps.
2. When F1 and F2 are correct, repeat the above procedures for F1 and F4. This may prove easier to do using the screw driver adjustments on the front panel since the front panel WIDTH control is only $1k\Omega$. When F1 and F4 are correct, check that all F keys are correct. With the FREQUENCY COUNTER, the frequencies are: $F1 = X$; $F2 = 2X$; $F3 = 4X$; $F4 = 8X$

FREQUENCY COUNTER METHOD

Press F1; adjust FREQ and/or PITCH for a convenient reading (such as 100Hz.); call this "X"

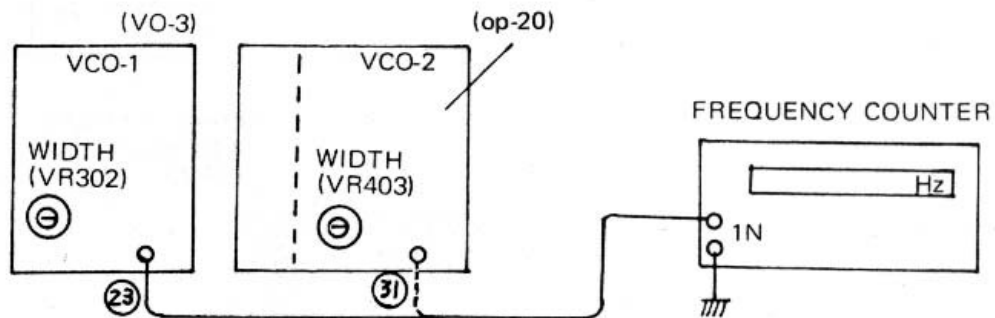

Press F2, note frequency; correct reading is $2X$. If the reading is high, adjust VR-302 so it is a little higher; if low, a little lower.

Press F1. If necessary, adjust VCO frequency for a reading which is easy to double mentally
Repeat the above steps until F2 reads twice $F1 \pm 1$ Hz

OSCILLOSCOPE/AUDIO GENERATOR METHOD

Connect the VERTICAL input lead to Terminal 23 on VO-3. Connect the HORIZONTAL lead to an audio generator. Set the generator for about 175 Hz.

Press F1; adjust FREQ for stable 1 : 1 Lissajous figure.

Press F2; Adjust VR-302 so the speed of the rolling increases slightly.

CAUTION: If the figure is turning slowly, be careful not to turn VR-302 in the direction which causes the pattern to reverse direction.

Press F1; adjust VCO frequency VR-17 for a stable 1 : 1 Lissajous figure.

Repeat the above steps until the figures for F1 and F2 remain stable.

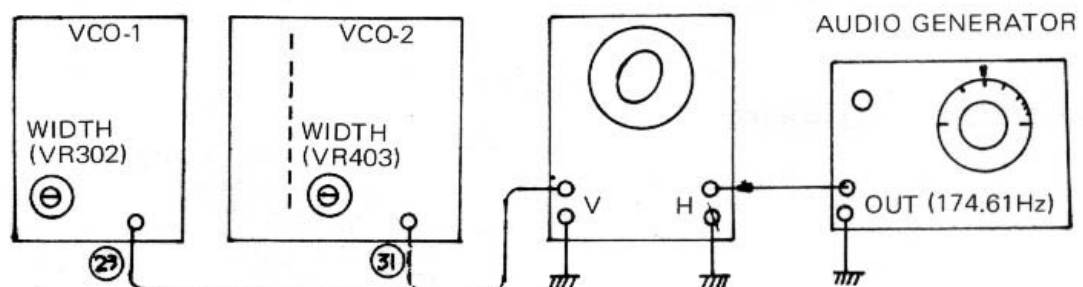

12-4-5

VCO-1 FREQUENCY ADJUSTMENT

VR-17

Set the front panel PITCH and TUNE controls at center;
 Press A2 and adjust VR-17 for A = 440 Hz.

- or for F1 = 174.61 Hz
- F2 = 349.23 Hz
- F3 = 698.46 Hz
- F4 = 1396 Hz.

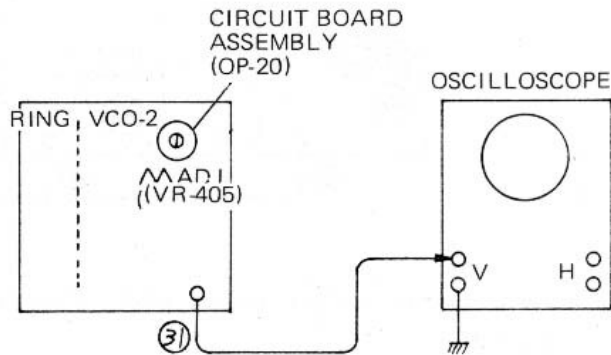
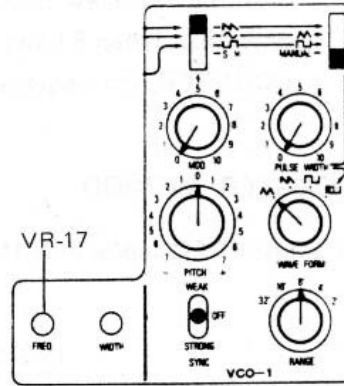

12-5 OP-20

12-5-1 VCO-2 Δ adjust

Adjust VR-405 for:

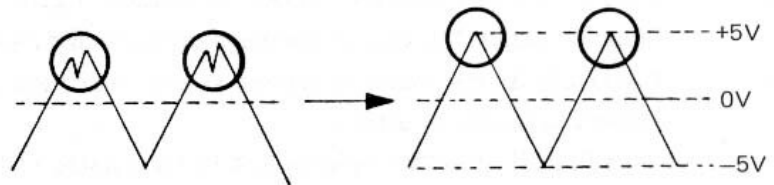
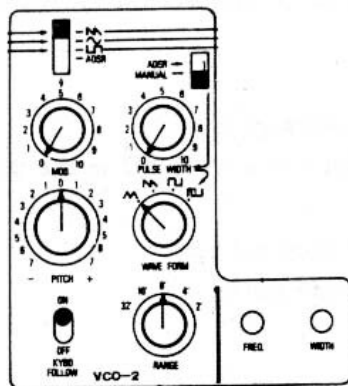

12-5-2 VCO-2 \square adjust

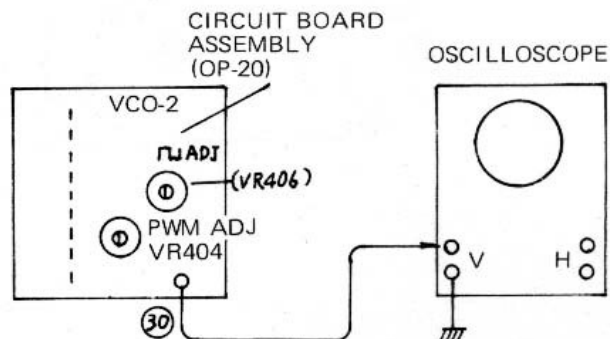

Adjust VR-406 for:

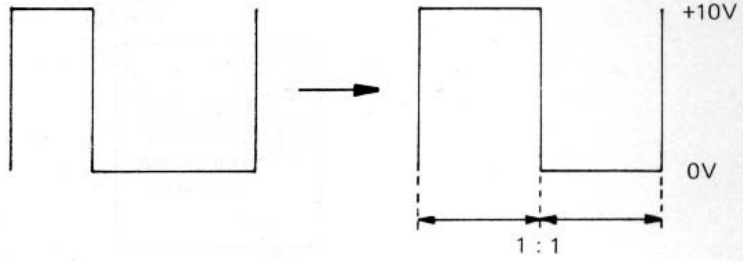
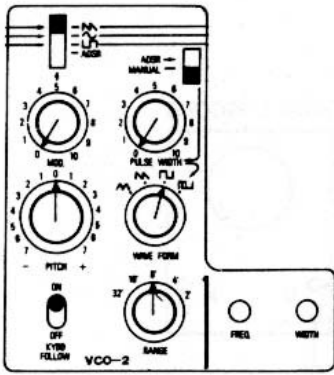

Adjust VR-404 for:

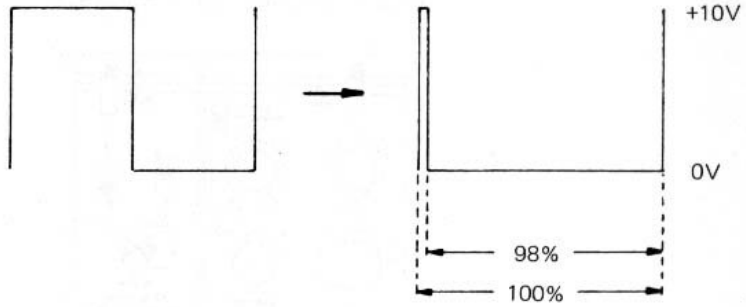
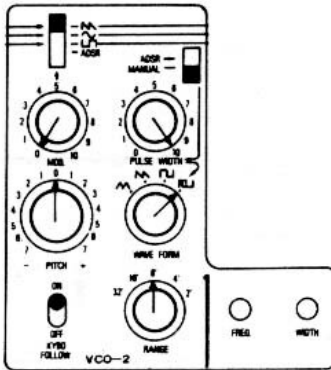

12-5-3 VCO-2 FREQUENCY WIDTH

The procedues are exactly the same as for VCO-1 (See 12-4-4)

12-5-4 VCO-2 FREQUENCY WIDTH

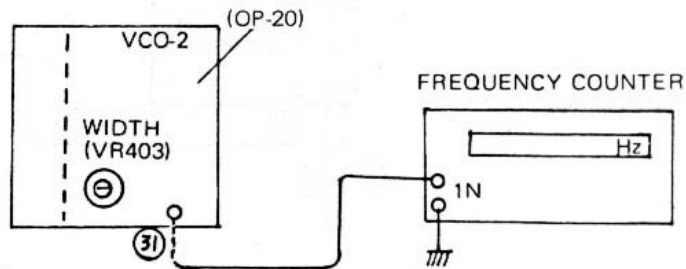

Set the front panel PITCH and TUNE controls at center; press A2 and adjust VR - 25 for A = 440 Hz.

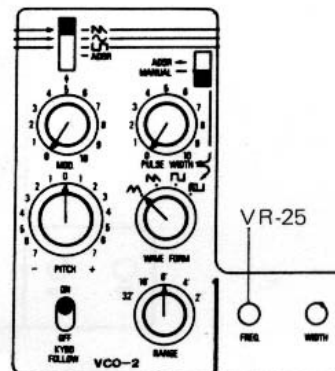
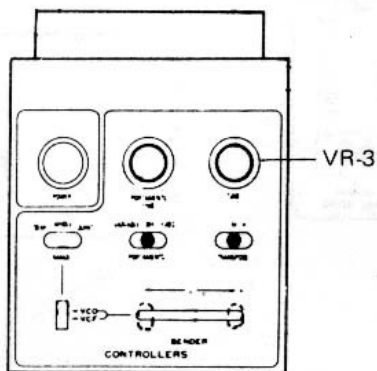

12-5-5 RING MODULATOR

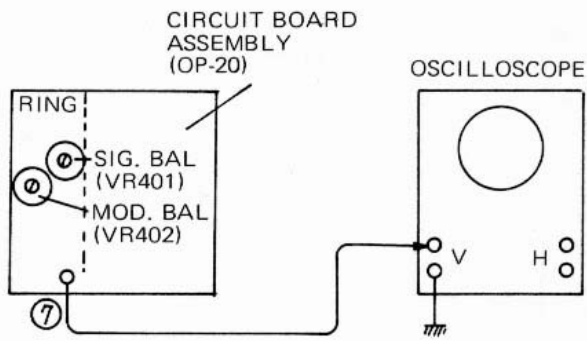

Adjust VR-401 for no leakage

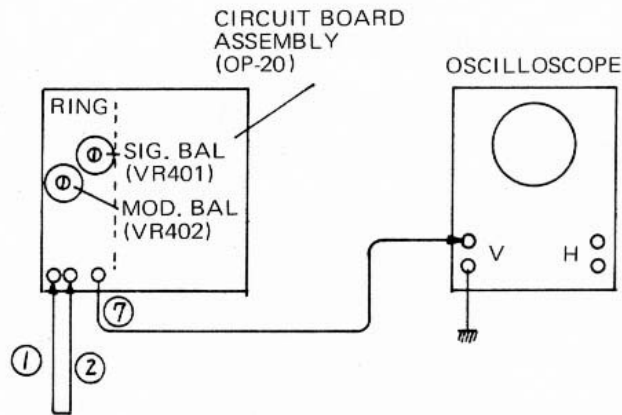
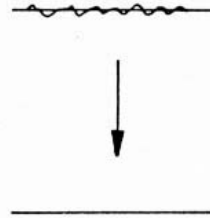
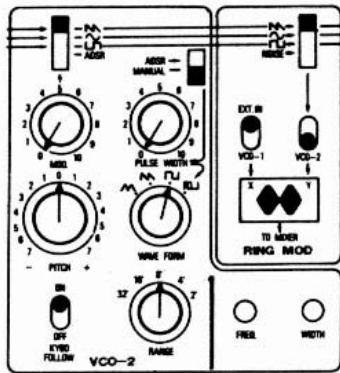

Short Terminal 2 to ground (Terminal 1). Adjust VR-402 for no leakage.

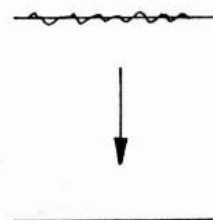
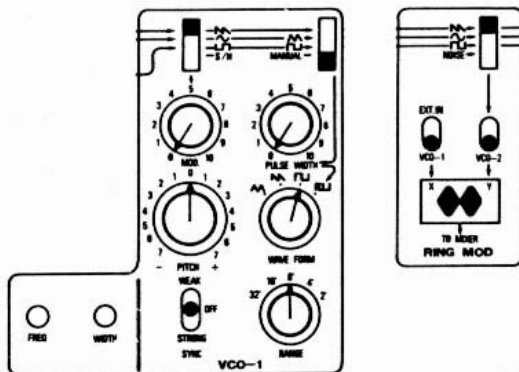

12-6 OP-21

(Speaker and amplifier are handy for the following)

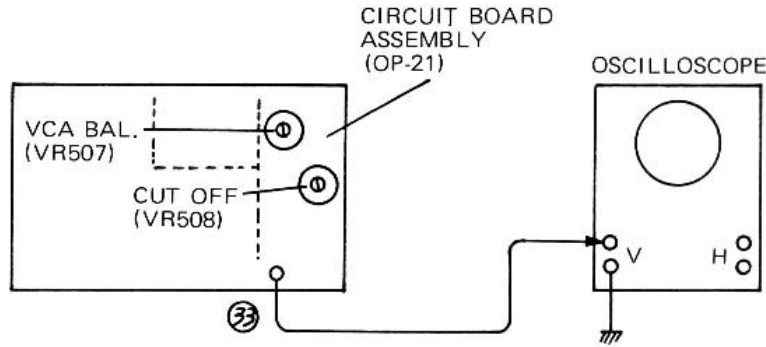

12-6-1 VCA Cutoff

Turn VR-508 all the way right; then turn left until signal just disappears. Make final adjustment with oscilloscope in most sensitive range (lower than 0.02V).

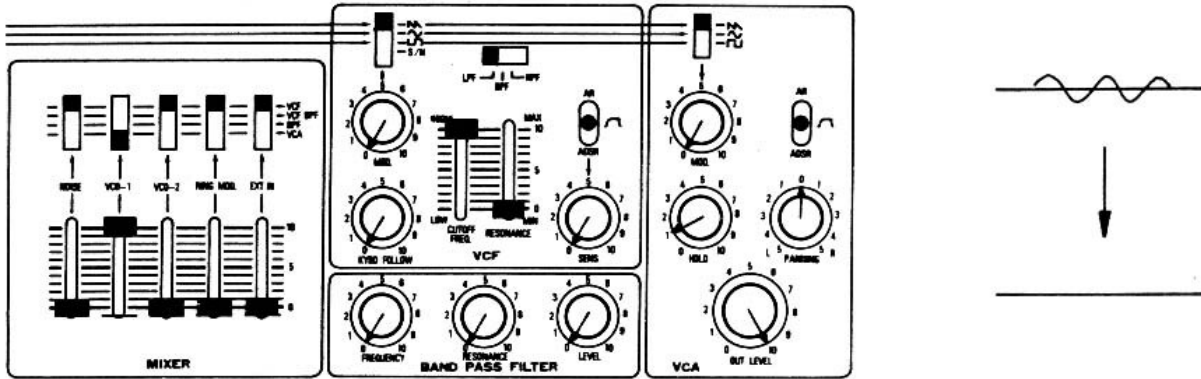

Gain check

Change the VCA HOLD control to "10" and confirm:



While tapping a key on the keyboard, adjust VR-507 for minimum ADSR click.

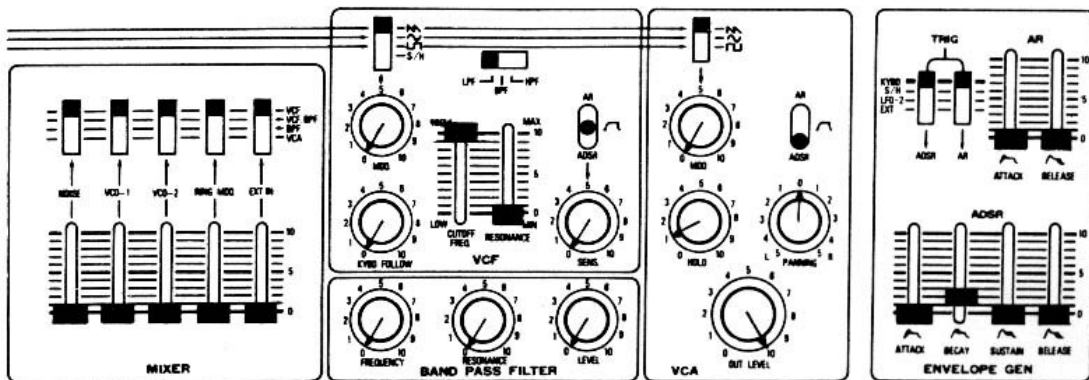

12-6-2 VCF

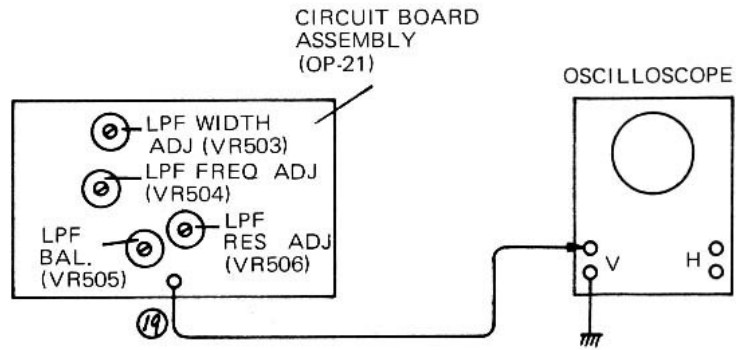

While tapping of the F1 key on the keyboard, adjust VR-505 for minimum ADSR click

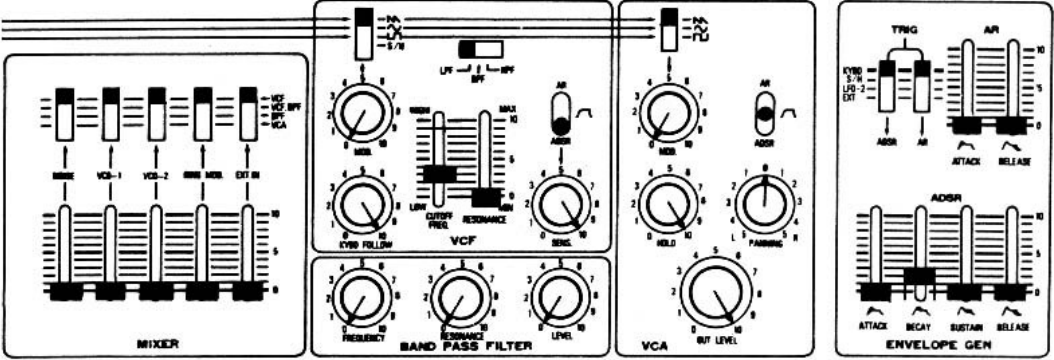

LPF Width
 Adjust VR-503 so frequency produced by F3 is twice F2.
 Confirm that $F2 = X$,
 $F3 = 2X$

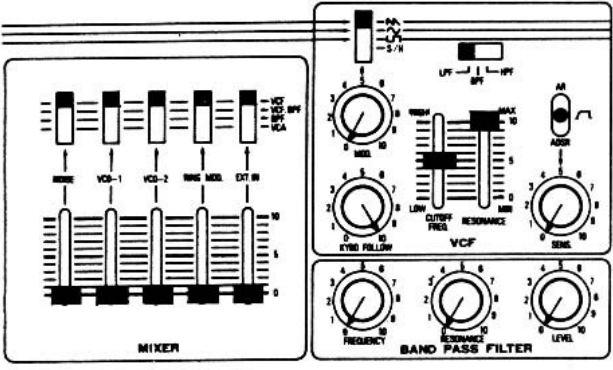

LPF Freq Press F1; adjust VR-504 for 20kHz.

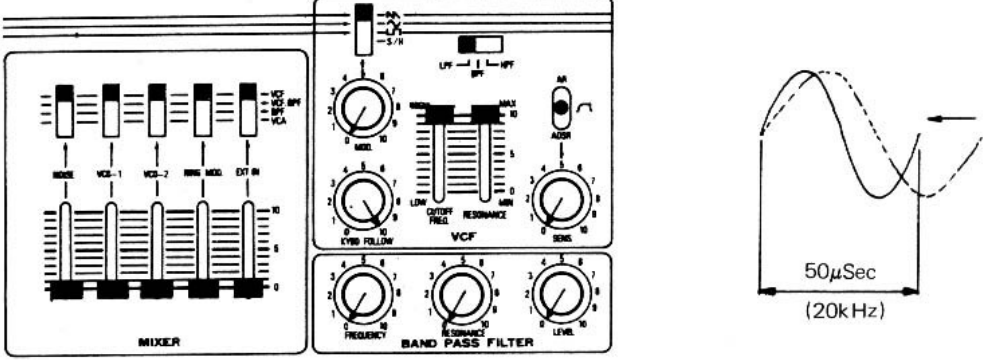

(If there is no wave form, turn VR-506 (OP-21) all the way left)

1976-10-30 SH-5

12-7 ADSR 0 Adjust

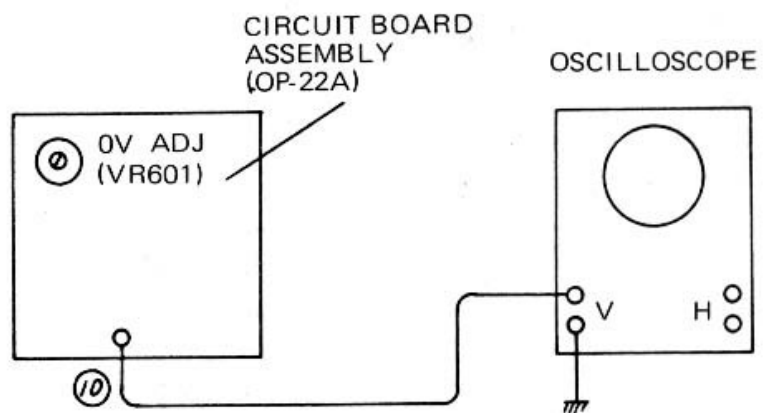

Use OSC 0.1V range or lower; adjust VR-601 for 0V DC.

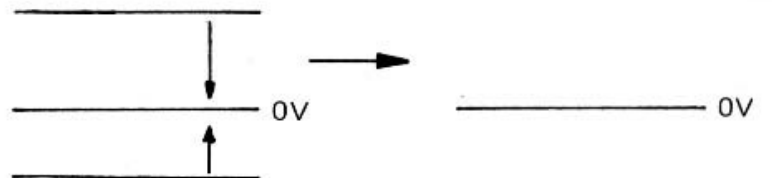
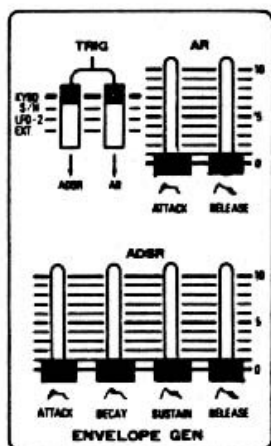

1976-10-30 SH-5

HPF Width Reset OSC Vertical for larger range and note reading produced by F1. Strike F2; adjust VR-502 for half (-6dB) reading.

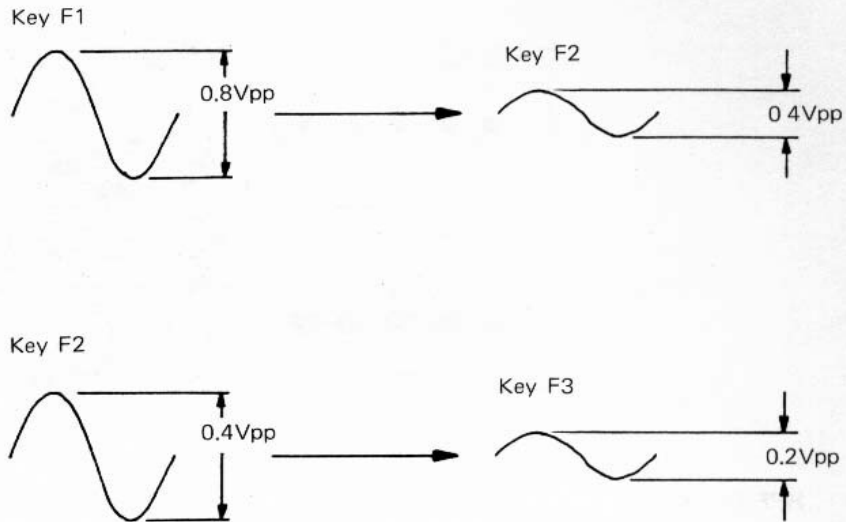

Repeat the above step until

$$F2 = 1/2 F1.$$

Check that $F3 = 1/2 F2$; $F4 = 1/2 F3$.

FPF Freq.
(Step-2)

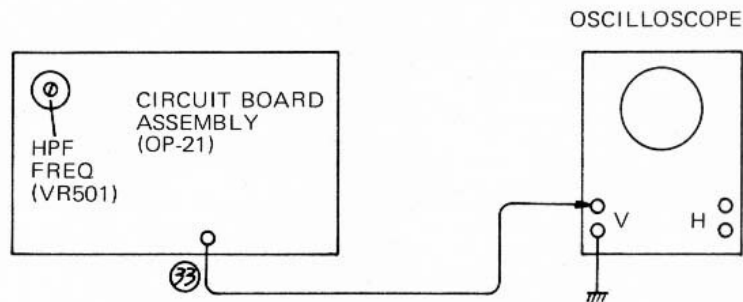

Press F2; adjust VR-501 so that base line is as straight as possible.

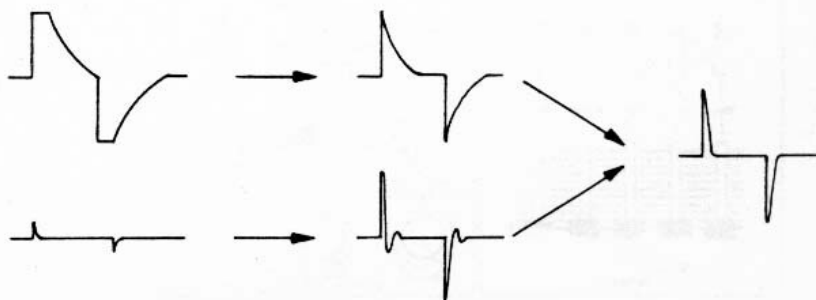
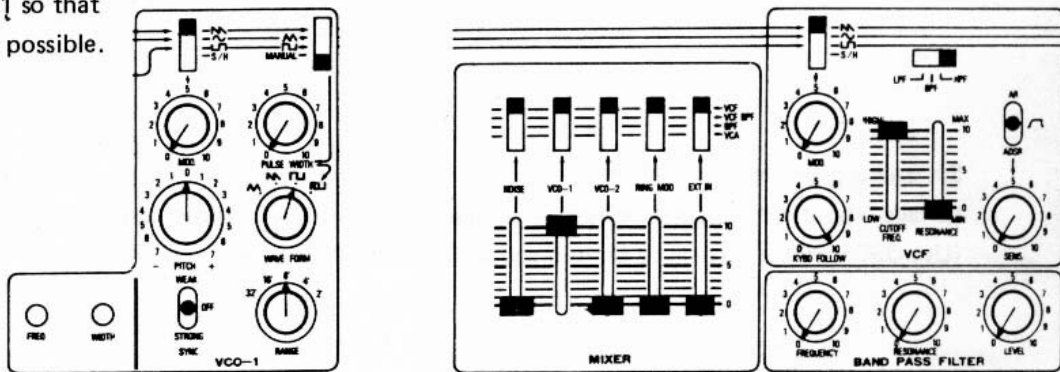

1976-10-30 SH-5

12-7 ADSR 0 Adjust

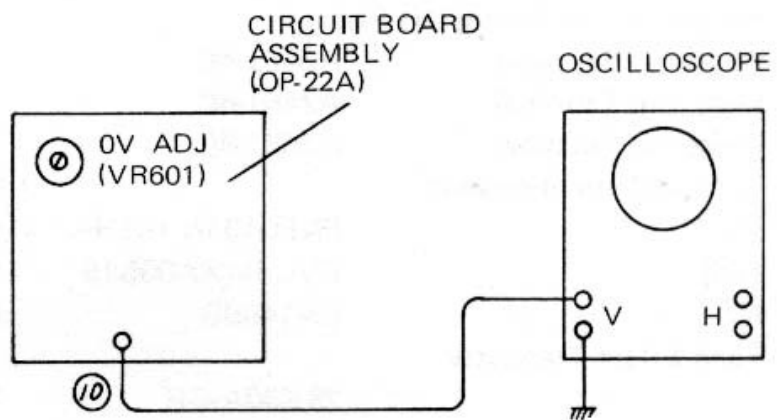

Use OSC 0.1V range or lower; adjust VR-601 for 0V DC.

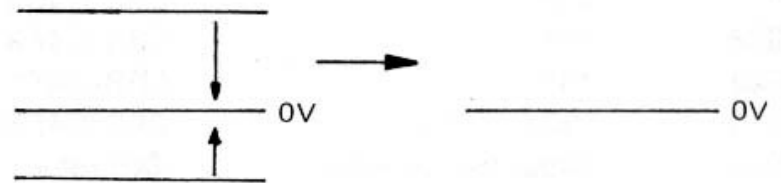
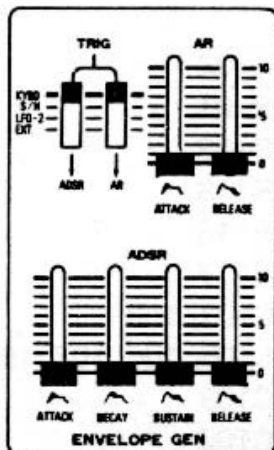

13. PARTS LIST

13-1 MANUAL BOARD ASSEMBLY OP-25A (149-025A)

052-131B	Printed Circuit Board, less Parts		
010-036	Wafer Pin Terminal	A2461-4C	
010-037	Wafer Pin Terminal	A2461-6C	
010-038	Wafer Pin Terminal	A2461-8C	
	Trimmer Potentiometer		
029-104	1K	PNB0403A-102H	VR101
028-007	100K	EVL-R4XA00B15	VR102, 103
020-052	IC	CA1458G	IC101, 102, 103
	Field Effect Transistor		
017-016	"	2SK30A-GR	Tr101
017-036	"	E-412	Tr102
017-012	Transistor	2SA733-Q	Tr103
017-013	Transistor	2SC945-Q	Tr104, 105
018-014	Diode	1S2473	D101, 102
	Metal Film Resistors		
044-822	100 Ohms	CRB-1/4FX 1%	R103
044-833	3.3 K	CRB-1/4FX 1%	R101
044-837	8.2K	CRB-1/4FX 1%	R102
044-838	10K	CRB-1/4FX 1%	R118
044-839	15K	CRB-1/4FX 1%	R116
044-848	150K	CRB-1/4FX 1%	R117
037-009	Capacitor, Ceramic	.001 mf	C101, 102
035-016	Capacitor, Mylar	.01 mf	C105, 106, 107, 108
035-024	Capacitor, Mylar	.047 mf	C109
035-034	Capacitor, Mylar	.33 mf	C103
032-101	Capacitor, Tantalum	10 mf/25V	C104

Serial No. Up to 440399

Printed Circuit Board 052-131B → 052-131A

Resistors 1/4W 5% are omitted.

13-2 CIRCUIT BOARD ASSEMBLY OP-19B (149-19B)

052-126C	Printed Circuit Board, less Parts		
010-036	Wafer Pin Terminal	A2461-4C	
010-037	Wafer Pin Terminal	A2461-6C	
010-038	Wafer Pin Terminal	A2461-8C	
022-077	Audio Transformers	ST-31	T201, 202
	Trimmer Potentiometer		
029-103	500 Ohms	PNB04C3A-501H	VR202
029-104	1K	PNB04C3A-102H	VR201
028-003	5K	EVL-R4XA00B53	VR206
028-004	10K	EVL-R4XA00B14	VR207
028-007	100K	EVL-R4XA00B15	VR203, 204, 205
020-010	IC	TA7504M	IC204, 205
020-052	IC	CA1458G	IC203
020-031	IC	LM723CN	IC201, 202
017-018	PUT	N13T-1 (N13T-2)	Tr222
017-014	Field Effet Transistor	2SK30A-Y	Tr216, 228, 229, 230
017-016	Field Effet Transistor	2SK30A-GR	Tr223, 225
017-039	Field Effet Transistor	NF510	Tr226
017-012	Transistor	2SA733-Q	Tr201, 221, 227
017-046	Transistor	2SC828-R	Tr208
017-013	Transistor	2SC945-Q	Tr202, 203, 204, 205, 206, 207, 208, 209, 210, 211, 212, 213, 214, 215, 217, 218, 219, 220, 224,

018-014	Diode	1S2473		D203, 204, 205, 206, 207, 208, 209, 210, 211, 212, 213, 214, 215, 216, 217, 218, 219
018-018	Diode	1N4002		D201, 202
	Metal Film Resistor			
044-829	820 Ohms	CRB-1/4FX	1%	R203
044-862	1.2K	CRB-1/4FX	1%	R205
044-831	1.5K	CRB-1/4FX	1%	R201
044-832	2.2K	CRB-1/4FX	1%	R206
044-863	2.7K	CRB-1/4FX	1%	R202
044-833	3.3K	CRB-1/4FX	1%	R207, 208
035-009	Capacitor, Mylar	.0022mf		C241
035-016	Capacitor, Mylar	.01mf		C222, 223, 226, 230, 233, 235, 236, 237, 238, 239, 240
035-018	Capacitor, Mylar	.015mf		C225
035-022	Capacitor, Mylar	.033mf		C229
035-024	Capacitor, Mylar	.047mf		C213, 220
035-028	Capacitor, Mylar	.1mf		C221, 232
037-005	Capacitor, Ceramic	47pf		C214
037-006	Capacitor, Ceramic	100pf		C202, 205, 208, 228
037-008	Capacitor, Ceramic	470pf		C201
032-099	Capacitor, Tantalum	1mf/35V		C231, 234
032-105	Capacitor, Tantalum	2.2mf/25V		C227
032-107	Capacitor, Tantalum	3.3mf/25V		C224
	Capacitor, Electrolytic			
032-033	10mf/16V	ECE-A16V10		C203, 204, 206, 207, 209, 210, 215, 216, 217, 218, 219
032-040	470mf/16V	ECE-A16V470		C211, 212

Serial No. Up to 440399

Printed Circuit Board

052-126C → 052-126B

Trimmer Potentiometer

VR207, 10K (B) → R1008, 4.7K 1/4R J

Resistors 1/4W 5% are omitted.

3-3 VCO BOARD ASSEMBLY VO-3A (152-003A)

052-127B	Printed Circuit Board, less parts			
010-036	Wafer Pin Terminal	A2461-4C		
010-037	Wafer Pin Terminal	A2461-6C		
010-038	Wafer Pin Terminal	A2461-8C		
	Trimmer Potentiometer			
020-106	10K	PNB04C3A-103H		VR302
028-007	100K	EVL-R4XA00B15		VR301, 303, 304
020-032	IC	A726		IC303
020-025	IC	CA3130T		IC304, 305
020-024	IC	301AH		IC306, 307, 308
020-010	IC	TA7504M		IC302
020-052	IC	CA1458G		IC301
	Field Effect Transistor			
017-016		2SK30A-GR		Tr301
017-012	Transistor	2SA733-Q		Tr302
017-013	Transistor	2SC945-Q		Tr303
018-014	Diode	1S2473		D301, 302, 303, 304
	Metal Film Resistor			
044-829	820 Ohms	CRB-1/4FX	1%	R317
044-838	10K	CRB-1/4FX	1%	R327, 328, 329, 330
044-840	22K	CRB-1/4FX	1%	R316
044-903	60K	CRB-1/4FX	1%	R313

1976-10-30 SH-5

044-845	82K	CRB-1/4FX	1%	R320
044-846	100K	CRB-1/4FX	1%	R301, 302, 303, 306
044-848	150K	CRB-1/4FX	1%	R319
044-851	220K	CRB-1/4FX	1%	R314
044-854	330K	CRB-1/4FX	1%	R304
044-857	560K	CRB-1/4FX	1%	R308
044-860	1 Meg	CRB-1/4FX	1%	R305, 312
037-001	Capacitor, Ceramic	10pf		C312, 313
037-006	Capacitor, Ceramic	100pf		C305, 310
035-005	Capacitor, Mylar	.001mf		C301, 316
035-016	Capacitor, Mylar	.01mf		C308, 309, 314, 315
035-111	Capacitor, Polystyrol	.001mf		C311
	Capacitor, Electrolytic	10mf/16V		
032-033	10mf/16V	ECE-A16V10		C306
032-036	47mf/16V	ECE-A16V47		C304, 307, 317
032-038	220mf/16V	ECE-A16V220		

Serial No. Up to 440399

Printed Circuit Board 052-127B → 052-127A

Capacitor, Electrolytic C317, 47mf/16V

Resistors 1/4W 5% are omitted.

13-4 CIRCUIT BOARD ASSEMBLY OP-20B (149-020B)

052-138B	Printed Circuit Board, less parts			
010-038	Wafer Pin Terminal	A2461-8C		
	Trimmer Potentiometer			
020-106	10K	PNB04C3A-103H		VR403
029-109	100K	PNB04C3A-104H		VR402
028-005	20K	EVL-R4XA00B24		VR401
028-007	100K	EVL-R4XA00B15		VR404, 405, 406
020-032	IC	A726		IC405
020-026	IC	LM1496N		IC401
020-025	IC	CA3130T		IC406, 407
020-024	IC	301AH		IC408, 409, 410
020-010	IC	TA7504M		IC404
020-027	IC	TA7136P		IC402
020-052	IC	CA1458G		IC403
017-016	Field Effect Transistor	2SK30A-GR		Tr402
017-012	Transistor	2SA733-Q		Tr403
017-013	Transistor	2SC945-Q		Tr401, 404, 405
018-014	Diode	1S2473		D401, 402, 403, 404, 405
	Metal Film Resistor			
044-829	820 Ohms	CRB-1/4FX	1%	R436
044-830	1K	CRB-1/4FX	1%	R402, 403, 417, 418
044-838	10K	CRB-1/4FX	1%	R442, 443, 448, 449
044-840	22K	CRB-1/4FX	1%	R435
044-903	60K	CRB-1/4FX	1%	R433
044-845	82K	CRB-1/4FX	1%	R439
044-846	100K	CRB-1/4FX	1%	R420, 421, 425
044-848	150K	CRB-1/4FX	1%	R440
044-851	220K	CRB-1/4FX	1%	R431
044-854	330K	CRB-1/4FX	1%	R419, 423
044-857	560K	CRB-1/4FX	1%	R427
044-860	1 Meg	CRB-1/4FX	1%	R424, 428, 434
037-001	Capacitor, Ceramic	10pf		C416, 419
037-005	Capacitor, Ceramic	47pf		C403, 404
037-006	Capacitor, Ceramic	100pf		C410, 413

035-005	Capacitor, Mylar	.001mf	C405, 420
035-016	Capacitor, Mylar	.01mf	C414, 415, 417, 418
035-028	Capacitor, Mylar	.1mf	C402
035-111	Capacitor, Polystyrol	.001mf	C409
032-099	Capacitor, Tantalum	1mf/35V	C401
	Capacitor, Electrolytic		
032-033	10mf/16V	ECE-A16V10	C411
032-036	47mf/16V	ECE-A16V47	C408, 412, 421
032-038	220mf/16V	ECE-A16V220	C406, 407

Serial No. Up to 440399

Printed Circuit Board 052-138B → 052-138A

Capacitor, Electrolytic C421, 47mf/16V

Resistors 1/4W 5% are omitted.

13-5 MIXER BOARD ASSEMBLY OP-23A (149-023A)

052-130A	Printed Circuit Board, less parts		
001-080	Switch	SQ24-12C	S701, 702, 703, 704, 705
	Potentiometer		
028-022	10K(B)	EVA-Q0AC16B14	VR701, 702, 703, 704, 705
020-027	IC	TA7136P	IC701
037-001	Capacitor, Ceramic	10pf	C704
037-005	Capacitor, Ceramic	47pf	C703, 706
037-013	Capacitor, Ceramic	.01mf	C701, 702
032-099	Capacitor, Tantalum	1mf/35V	C705
032-033	Capacitor, Electrolytic	10mf/16V	C707, 708

Resistors 1/4W 5% are omitted.

13-6 CIRCUIT BOARD ASSEMBLY OP-21B (149-021B)

052-128C	Printed Circuit Board, less parts		
010-036	Wafer Pin Terminal	A2461-4C	
010-037	Wafer Pin Terminal	A2461-6C	
010-038	Wafer Pin Terminal	A2461-8C	
	Trimmer Potentiometer		
028-004	10K	EVL-R4XA00B14	VR502, 503, 506
028-007	100K	EVL-R4XA00B15	VR501, 504, 507, 508
020-010	IC	TA7504M	IC508
020-052	IC	CA1458G	IC503, 509, 510
020-024	IC	301AH	IC511
020-015	IC	CA3080 (RE)	IC502, 507, 505
020-027	IC	TA7136P	IC501, 506
020-021	IC	ITS1276	IC504
017-014	Field Effect Transistor	2SK30A-Y	Tr501
017-012	Transistor	2SA733-Q	Tr504, 505, 523
017-013	Transistor	2SC945-Q	Tr503, 508, 509, 510, 511, 512, 513, 514, 515, 524
017-047	Transistor	2SC945-Q (selected)	Tr516, 517, 518, 519
017-003	Transistor	2SC1000-GR	Tr502, 520
017-048	Transistor	2SC1000-GR (selected)	Tr506, 507
018-014	Diode	1S2473	D501, 502, 503, 504, 505, 506
037-014	Capacitor, Ceramic	5pf	C515, 517
037-001	Capacitor, Ceramic	10pf	C533
037-005	Capacitor, Ceramic	47pf	C502, 506
037-006	Capacitor, Ceramic	100pf	C534

1976-10-30 SH-5

037-007	Capacitor, Ceramic	250pf	C503, 522
035-005	Capacitor, Mylar	.001mf	C505, 526
035-009	Capacitor, Mylar	.002mf	C501
035-016	Capacitor, Mylar	.01mf	C518, 519, 524, 525, 530, 531, 535, 536
035-020	Capacitor, Mylar	.022mf	C509, 529, 532
035-026	Capacitor, Mylar	.068mf	C510, 511, 512, 513
032-099	Capacitor, Tantalum	1mf/35V	C514, 516,
	Capacitor, Electrolytic		
032-191	10mf/16V	ECE-A16N10	C523
032-033	10mf/16V	ECE-A16V10	C504, 507, 508, 520
032-038	220mf/16V	ECE-A16V220	C527, 528

Serial No. Up to 440399

Printed Circuit Board 052-128C → 052-128B

Resistors 1/4W 5% are omitted.

13-7 CIRCUIT BOARD ASSEMBLY OP-22A (149-022A)

052-129B	Printed Circuit Board, less parts		
010-036	Wafer Pin Terminal	A2461-4C	
010-037	Wafer Pin Terminal	A2461-6C	
010-038	Wafer Pin Terminal	A2461-8C	
	Trimmer Potentiometer		
028-002	1K	EVL-R4XA00B13	VR601
	Field Effect Transistor		
017-014		2SK30A-Y	Tr610
017-018	PUT	N13T-1	Tr607
017-011	Transistor	2SC373	Tr608
017-012	Transistor	2SA733-Q	Tr602, 605, 606, 609, 612
017-012	Transistor	2SC945-Q	Tr601, 603, 604, 611, 613, 614, 615, 616, 618, 619, 620, 621, 622, 623, 624, 625, 626
018-014	Diode	1S2473	D601, 602, 603, 604, 605, 606, 607, 608, 609
035-005	Capacitor, Mylar	.001mf	C601, 605, 607
035-016	Capacitor, Mylar	.01mf	C611, 614, 617
035-028	Capacitor, Mylar	.1mf	C610, 612, 613, 615, 616, 618
032-099	Capacitor, Tantalum	1mf/35V 10%	C608
032-107	Capacitor, Tantalum	3.3mf/25V 10%	C602, 606
	Capacitor, Electrolytic		
032-038	220mf/16V	ECE-A16V220	C603, 604

Serial No. Up to 440399

Printed Circuit Board 052-129B → 052-129

Resistors 1/4W 5% are omitted.

13-8 POWER SUPPLY BOARD ASSEMBLY PS-17A (146-017A)

052-133B	Printed Circuit Board, less parts		
048-032	Heatsink		
010-038	Wafer Pin Terminal	A2461-8C	
018-028	Diode	ESAB01-03C	D802, 804
018-029	Diode	ESAB01-03N	D801, 803
018-022	Diode	1N4003	D805, 806
017-010	Transistor	2SD234-0	Tr801, 802
020-031	IC	LM723CN	IC801, 802
	Trimmer Potentiometer		

1976-10-30 SH-5

028-002	1K	EVL-R4XA00B13	VR801, 802
037-008	Capacitor, Ceramic	470pf	C803, 804
	Capacitor, Electrolytic		
032-033	10mf/16V	ECE-A16V10	C805, 806
032-082	470mf/16V	ECE-A16V470	C801, 802

Resistors 1/4W 5% are omitted.

13-9 POWER SUPPLY BOARD ASSEMBLY PS-23A (146-023A)

052-133B	Printed Circuit Board, less parts		
048-032	Heatsink		
010-038	Wafer Pin Terminal	A2461-8C	
018-028	Diode	ESAB01-03C	D802, 804
018-029	Diode	ESAB01-03N	D801, 803
018-022	Diode	1N4003	D805, 806
017-010	Transistor	2SD234-0	Tr801, 802
020-031	IC	LM723CN	IC801, 802
	Trimmer Potentiometer		
028-002	1K	EVL-R4XA00B13	VR801, 802
037-008	Capacitor Ceramic	470pf	C803, 804
	Capacitor, Electrolytic		
032-033	10mf/16V	ECE-A16V10	C805, 806
032-082	470mf/16V	ECE-A16V470	C801, 802
008-024	Fuse	SGA 0.500	F801, 802
012-003	Fuse Holder	TF-758	
076-049	Fuse Mark		

Resistors 1/4W 5% are omitted.